

NOTES:

(NI) 1. FIT / FORM / FUNCTION SHALL FOLLOW PS-E.008.

BILL OF MATERIAL (CURRENT LEVEL)

ITEM	PT/ASSY	DESCRIPTION	TYPE	QTY.
1	2-990	TUB AND SHOWER PLATE ASM	ASSEMBLY	1
2	2-989	COLLAR ASM	ASSEMBLY	1
3	91308	TEMP LIMIT STOP - THERMO	PART	1
4	12344	HANDLE BONNET	PART	1
5	12345	SLEEVE - THERMO	PART	1
6	2-991	THERMO BONNET ASM	ASSEMBLY	1
7	2-261	THERMO HDL ASM - TRAD	ASSEMBLY	2
8	92113	SCRW, M4 X .7 X 40 PHL FLT	HDP	2

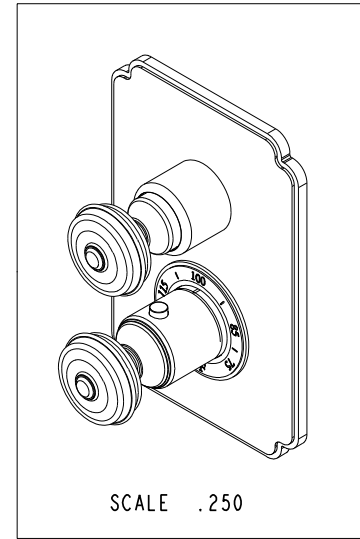
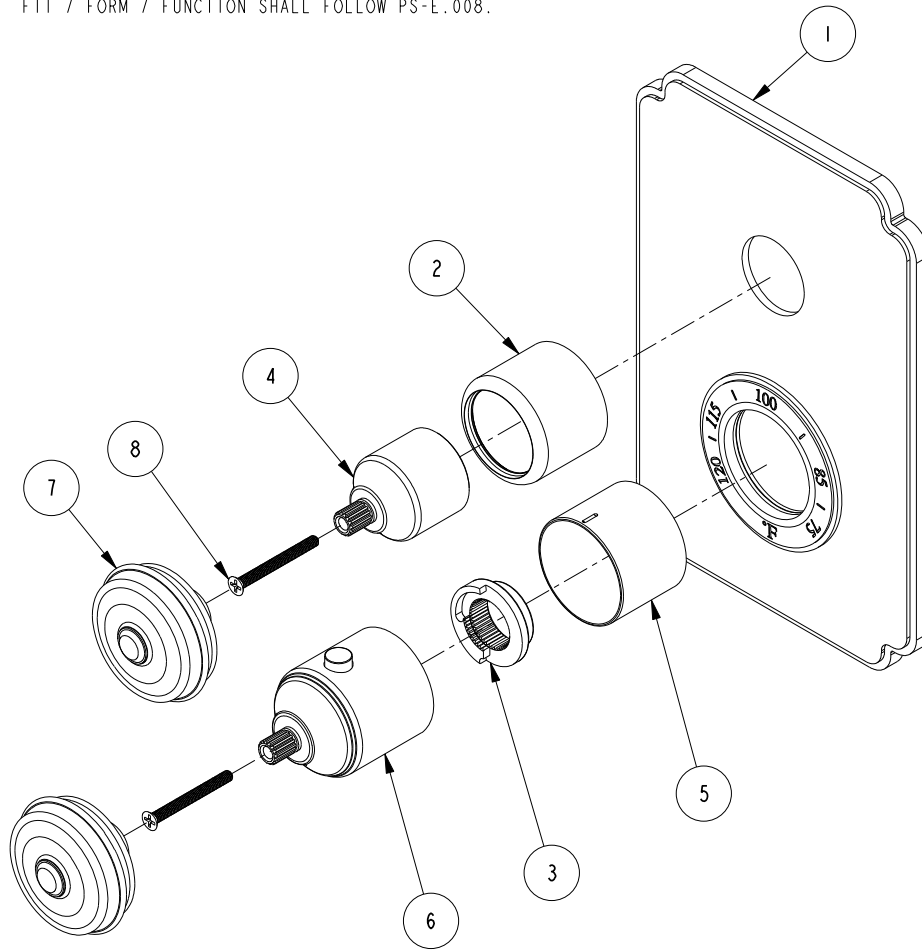

TESTING	-	-	-
ASSEMBLY	-	-	-
PLATING	-	-	-
POLISHING	-	NEXT ASSY	USED ON
MACHINING	-	APPLICATION	
TOOLING	FIXTURE #	REMOVE ALL BURRS AND SHARP EDGES	

UNITS ARE: INCHES [MM]
 TOLERANCES ARE:
 FRACTIONS DECIMALS ANGLES
 $\pm 1/16"$.X $\pm .1$ [2,5] $\pm 1^\circ$
 .XX $\pm .06$ [1,5]
 (X.XXX) DENOTES CRITICAL DIMS.
 ALL THREADS ARE CRITICAL

BRASSTECH 2001 CARNEGIE AVE.
 INCORPORATED SANTA ANA, CA 92705
 (949) 417-5207

THERMO TUB / SHOWER

-	B	EN-3236	01/17/17	J.M.	COPYRIGHT 2005 BRASSTECH, INC. THESE DRAWINGS AND THE DESIGNS DEPICTED HEREIN ARE THE PROPRIETARY PROPERTY OF BRASSTECH. ANY USE OR REPRODUCTION IS SUBJECT TO THE EXPRESS APPROVAL OF BRASSTECH. UNAUTHORIZED USE IS STRICTLY PROHIBITED. ALL RIGHTS RESERVED.
-	A	EN-2775h	11/20/15	J.M.	
-	-	EN-2775f	08/20/15	J.M.	
ZONE	REV	DESCRIPTION	DATE	APPROVED	

DRAWN VINAY 01/17/17
 CHECKED RAVINDRA 01/17/17
 APPROVED J.M. 01/17/17

DWG NO.	3-803TS	REV	B
SCALE	.375	REF.	-
SHEET	1	OF	2

