

NOTES:

1. TO INSPECT ASSEMBLY, FOLLOW FIRST ARTICLE AND IN PROCESS INSPECTION SHEET.

BILL OF MATERIAL (CURRENT LEVEL)

ITEM	PT/ASSY	DESCRIPTION	TYPE	QTY.
1	2-225	BP COVER PLATE FOR SHOWER	ASSEMBLY	1
2	3-159	TRIM KIT - STOP VALVE	ASSEMBLY	1
3	200	SHOWER ARM 6" BRASS	PART	1
4	206	SHOWER ARM FLANGE	PART	1
5	2156	SHOWER HEAD, TRAD	ASSEMBLY	1

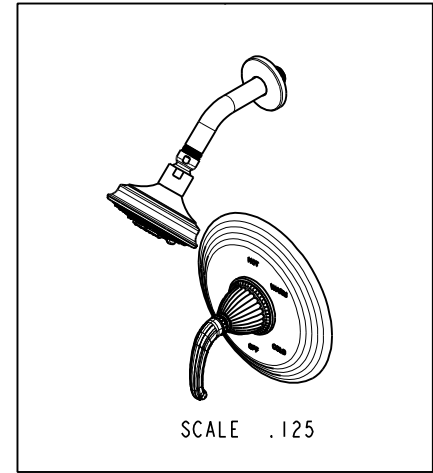
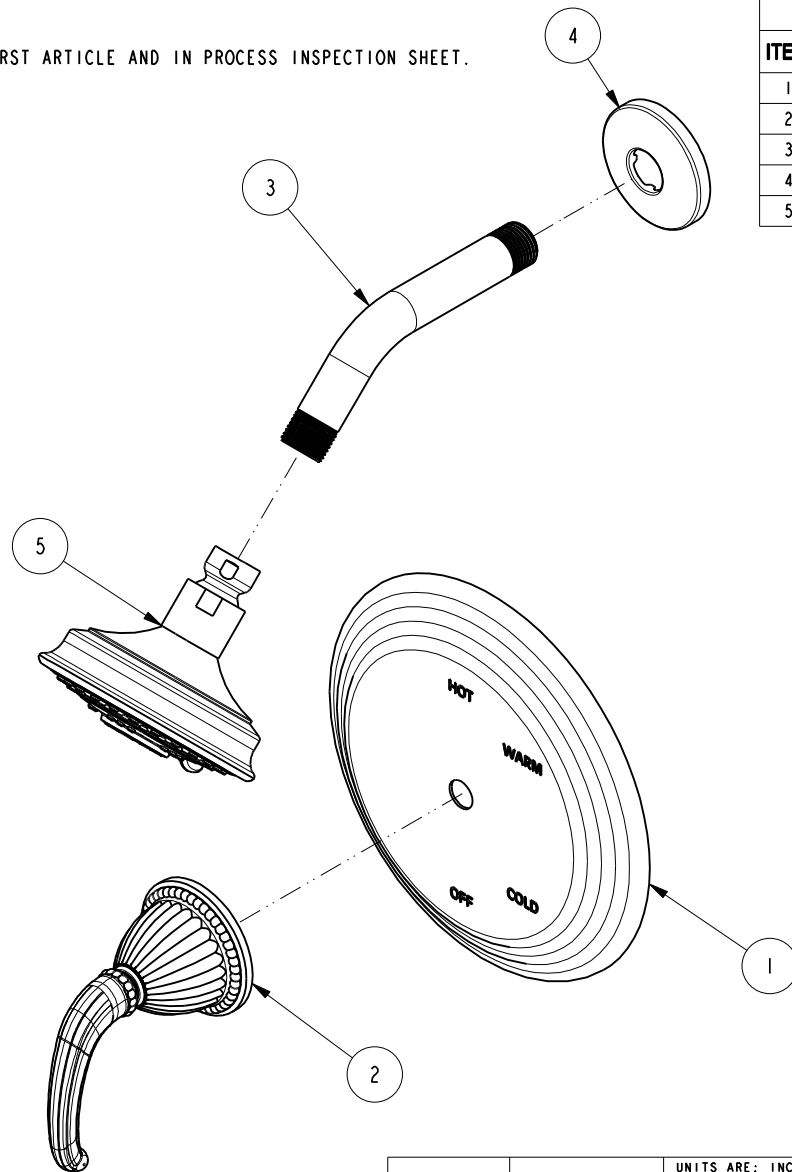

ZONE	REV	DESCRIPTION	DATE	APPROVED
-	E	EN-4300e	04/28/21	R.S.
-	D	EN-2802	09/04/14	-
-	C	EN-1745	08/22/11	-
-	B	EN-1183	03/23/09	-
-	A	EO-0224	07/01/03	-

COPYRIGHT 2005 BRASSTECH, INC. THESE DRAWINGS AND THE DESIGNS DEPICTED HEREIN ARE THE PROPRIETARY PROPERTY OF BRASSTECH. ANY USE OR REPRODUCTION IS SUBJECT TO THE EXPRESS APPROVAL OF BRASSTECH. UNAUTHORIZED USE IS STRICTLY PROHIBITED. ALL RIGHTS RESERVED.

TESTING	ASSEMBLY	PLATING	POLISHING	MACHINING
-	-	-	-	-
-	-	-	-	-
-	-	-	-	-
-	-	-	-	-
TOOLING FIXTURE #	REMOVE ALL BURRS AND SHARP EDGES			

UNITS ARE: INCHES [MM]			
TOLERANCES ARE:			
FRACTIONS DECIMALS		ANGLES	
±1/16"		±°	
.x ±.1 [2,5]		.xx ±.06 [1,5]	
ⓧ.XXX DENOTES CRITICAL DIMS.			
ALL THREADS ARE CRITICAL			
DRAWN	JINSON	04/28/21	
CHECKED	R.S.	04/28/21	
APPROVED	R.S.	04/28/21	

BRASSTECH 2001 CARNEGIE AVE.
INCORPORATED SANTA ANA, CA 92705
(949) 417-5207

TRIM KIT - BP SHOWER SET

DWG NO. **3-884BP** REV **E**

SCALE .300 REF. - SHEET 1 OF 2

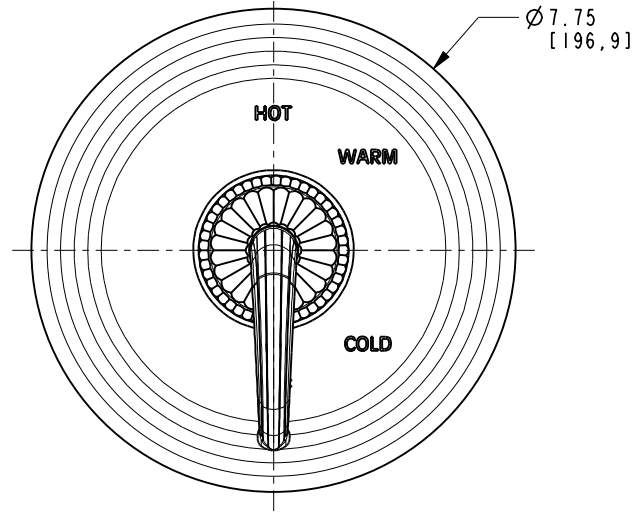
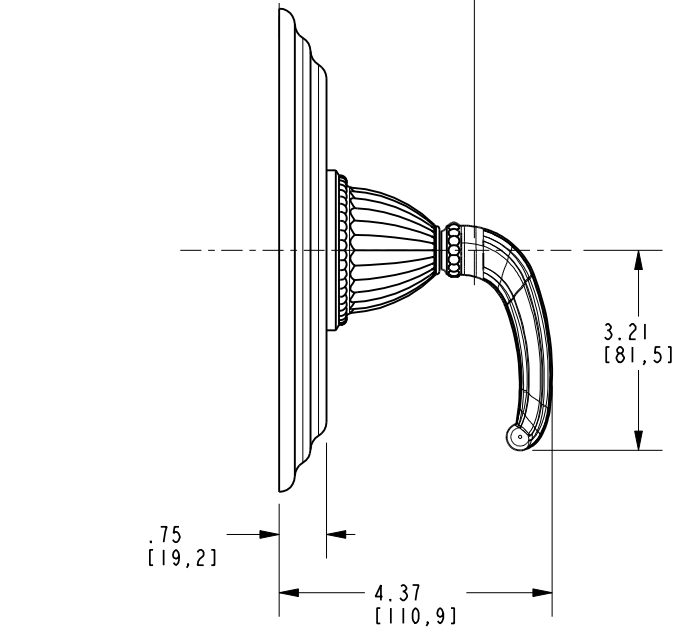
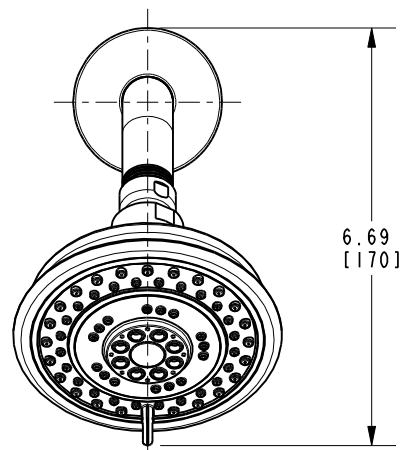
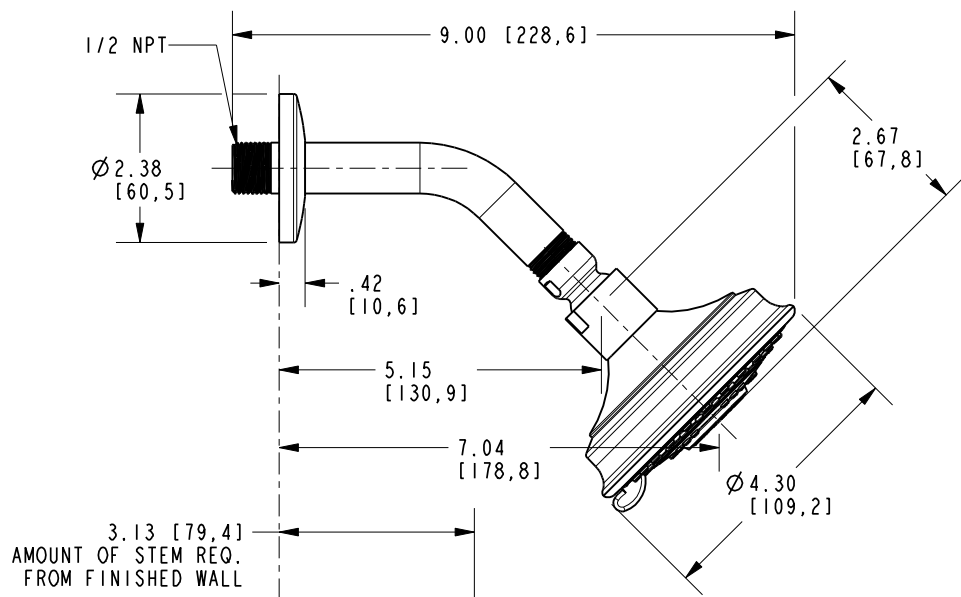

BRASSTECH		2001 E. CARNEGIE AVE. SANTA ANA, CA 92705 (949) 417-5207	
INCORPORATED			
DWG NO.	3-884BP		REV E
SCALE	.325	REF.	-
SHEET 2		OF 2	