

NOTES:

1. TO INSPECT ASSEMBLY, FOLLOW FIRST ARTICLE AND IN PROCESS INSPECTION SHEET.

BILL OF MATERIAL (CURRENT LEVEL)

ITEM	PT/ASSY	DESCRIPTION	TYPE	QTY.
1	12171	ESCUTCHEON, ROMAN TUB	PART	2
2	10523	HEX ESCUTCHEON BONNET	PART	2
3	2-141	HANDLE ONLY, HOT	ASSEMBLY	1
4	2-142	HANDLE ONLY, COLD	ASSEMBLY	1
5	3-178	ROMAN TUB SPOUT	ASSEMBLY	1
6	91753	O-RING, # 2-136, EP, 50 DURO - GREY	PART	2

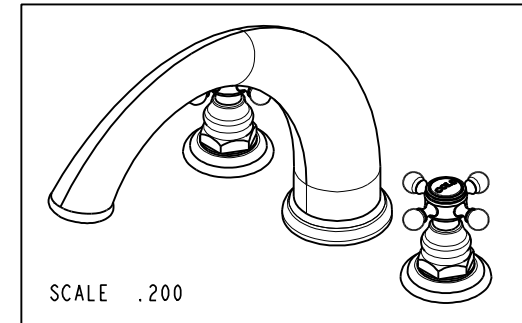
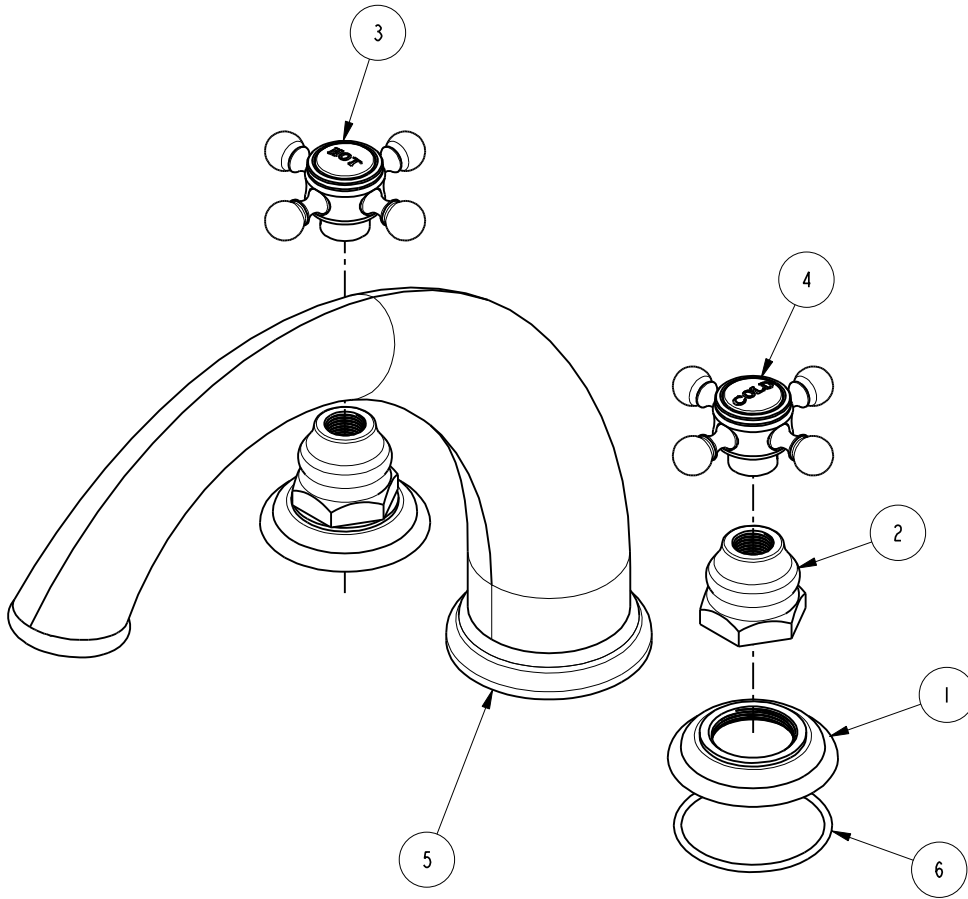

ZONE	REV	DESCRIPTION	DATE	APPROVED
-	D	EN-4300u	02/02/21	R.S.
-	C	EN-3722	02/08/19	C.G.
-	B	EN-2519b	12/09/15	AN
-	A	EN-2032	01/07/14	-

COPYRIGHT 2005 BRASSTECH, INC. THESE DRAWINGS AND THE DESIGNS DEPICTED HEREIN ARE THE PROPRIETARY PROPERTY OF BRASSTECH. ANY USE OR REPRODUCTION IS SUBJECT TO THE EXPRESS APPROVAL OF BRASSTECH. UNAUTHORIZED USE IS STRICTLY PROHIBITED. ALL RIGHTS RESERVED.

TESTING	-	-	-
ASSEMBLY	-	-	-
PLATING	-	-	-
POLISHING	-	NEXT ASSY	USED ON
MACHINING	-	APPLICATION	
TOOLING FIXTURE #	REMOVE ALL BURRS AND SHARP EDGES		

UNITS ARE: INCHES [MM]		
TOLERANCES ARE:		
FRACTIONS	DECIMALS	ANGLES
±1/16"	.X ±.1 [2.5]	±°
	.XX ±.06 [1.5]	
(X.XXX) DENOTES CRITICAL DIMS.		
ALL THREADS ARE CRITICAL		
DRAWN	JINSON	02/02/21
CHECKED	R.S.	02/02/21
APPROVED	R.S.	02/02/21

BRASSTECH 2001 CARNEGIE AVE.
INCORPORATED SANTA ANA, CA 92705
(949) 417-5207

TRIM KIT - ROMAN TUB

DWG NO. **3-896** REV **D**

SCALE .375 REF. - SHEET 1 OF 3

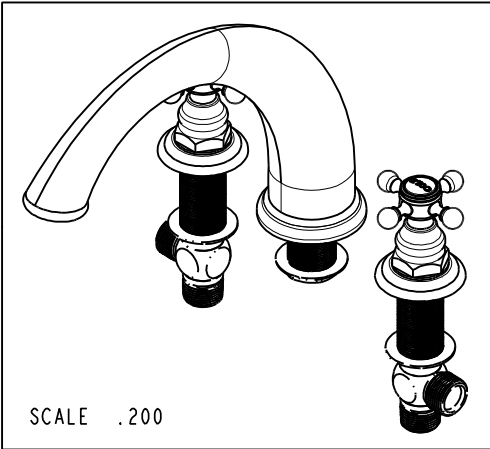
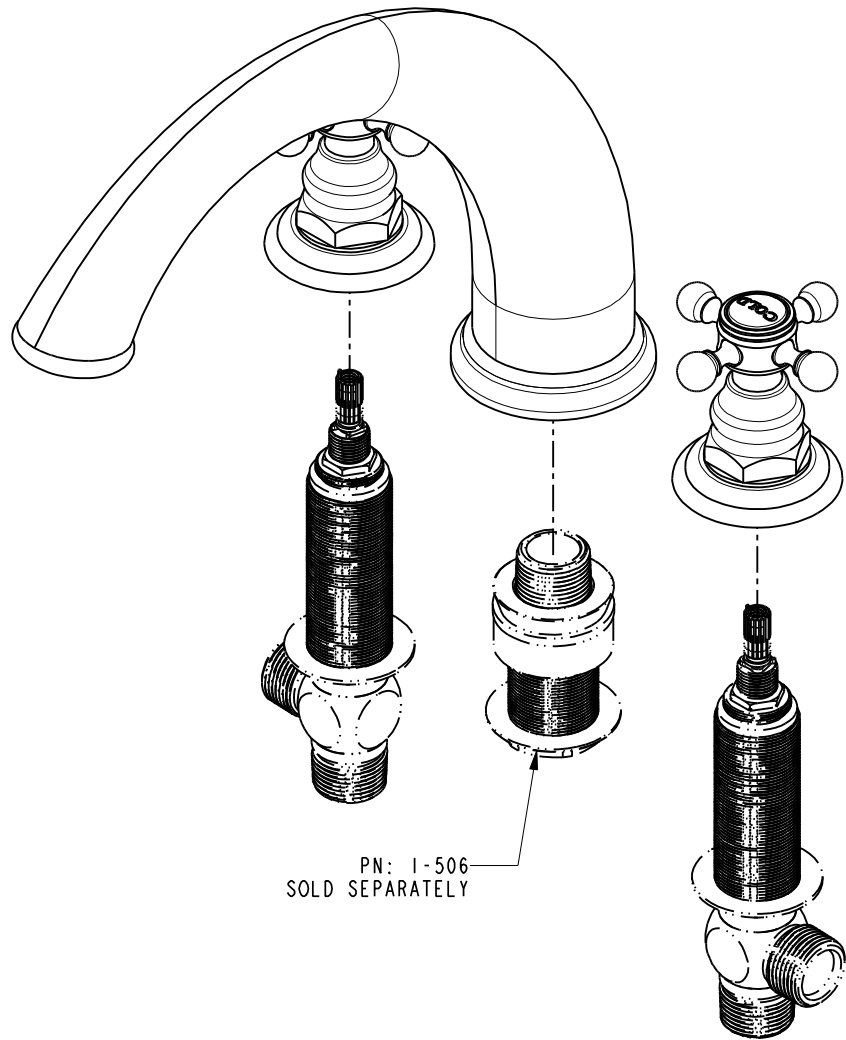

BRASSTECH

2001 CARNEGIE AVE.
SANTA ANA, CA 92705
(949) 417-5207

INCORPORATED		REV
DWG NO.	3-896	D
SCALE .375	REF. -	SHEET 2 OF 3

