

NOTES:

1. TO INSPECT ASSEMBLY, FOLLOW FIRST ARTICLE AND IN PROCESS INSPECTION SHEET.

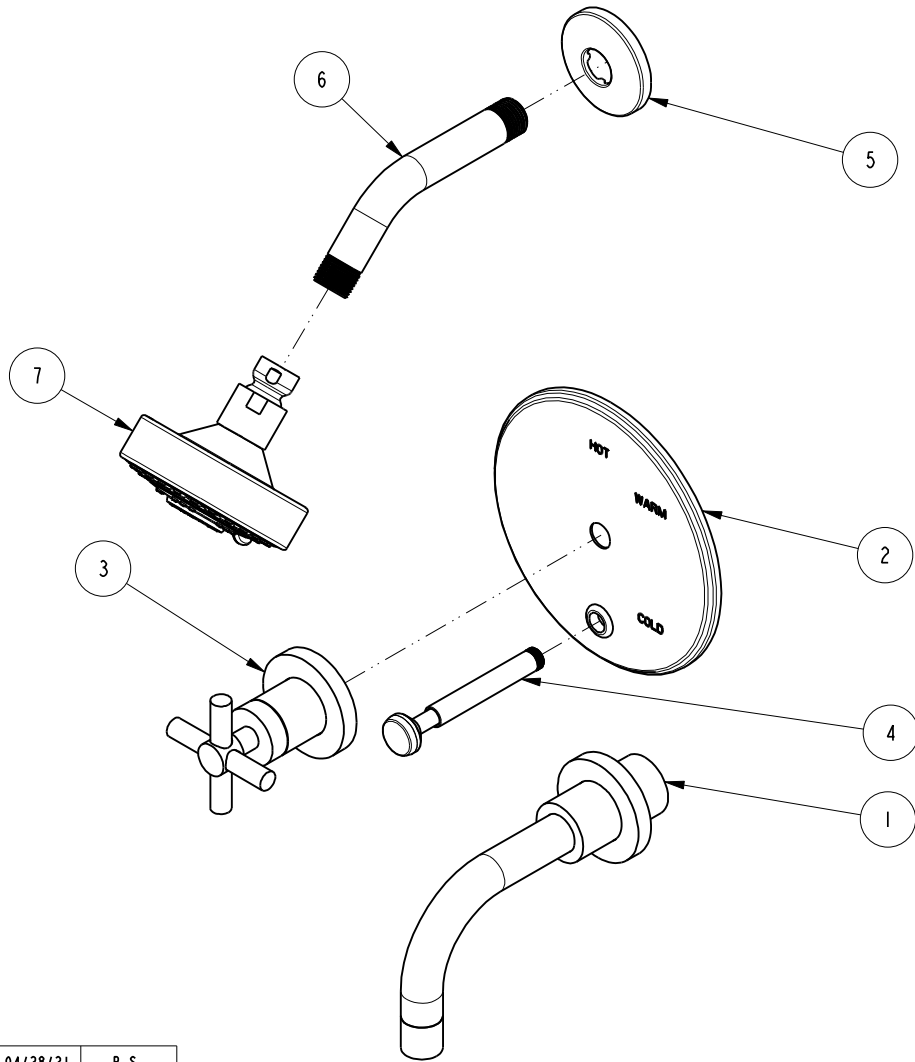

BILL OF MATERIAL (CURRENT LEVEL)

ITEM	PT/ASSY	DESCRIPTION	TYPE	QTY.
1	3-234	WALL TUB SPOUT ASM	ASSEMBLY	I
2	2-438	COVERPLATE BP W/DIV ASM	ASSEMBLY	I
3	3-227	HANDLE TRIM - STOP VALVE	ASSEMBLY	I
4	2-217	DIVERTER TRIM KIT	ASSEMBLY	I
5	206	SHOWER ARM FLANGE	PART	I
6	200	SHOWER ARM 6" BRASS	PART	I
7	2155	SHOWER HEAD, CONTEMP	ASSEMBLY	I

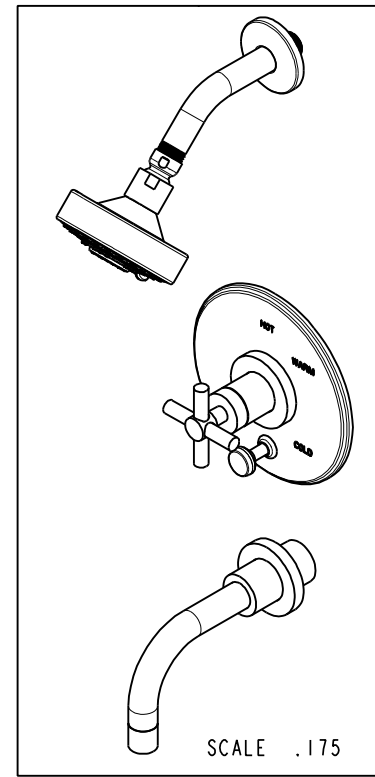

ZONE	REV	DESCRIPTION	DATE	APPROVED
-	G	EN-4300e	04/28/21	R.S.
-	F	EN-2802	09/05/14	-
-	D	EN-1745	08/22/11	-
-	C	EN-1544	04/28/10	-
-	B	EO-0872	09/05/07	-
-	A	-	-	-
-	-	RELEASED	-	-

COPYRIGHT 2005 BRASSTECH, INC.
 THESE DRAWINGS AND THE DESIGNS
 DEPICTED HEREIN ARE THE PROPRIETARY
 PROPERTY OF BRASSTECH. ANY USE
 OR REPRODUCTION IS SUBJECT TO
 THE EXPRESS APPROVAL OF BRASSTECH.
 UNAUTHORIZED USE IS STRICTLY
 PROHIBITED. ALL RIGHTS RESERVED.

TESTING	ASSEMBLY	PLATING	POLISHING	MACHINING	TOOLING FIXTURE #
-	-	-	-	-	-
-	-	-	-	-	-
-	-	-	-	-	-
-	-	-	-	-	-
-	-	-	-	-	-

UNITS ARE: INCHES [MM]	
TOLERANCES ARE:	
FRACTIONS	DECIMALS
±1/16"	±.1
	±.06
(X.XXX)	DENOTES CRITICAL DIMS.
ALL THREADS ARE CRITICAL	
DRAWN	JINSON 04/28/21
CHECKED	R.S. 04/28/21
APPROVED	R.S. 04/28/21

BRASSTECH 2001 CARNEGIE AVE.
 INCORPORATED SANTA ANA, CA 92705
 (949) 417-5207

TRIM KIT 3-992BP

DWG NO.	REV
3-992BP	G
SCALE .250	REF. -
SHEET 1 OF 2	

4 3 2 1

D
C
B
A

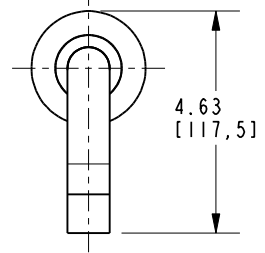
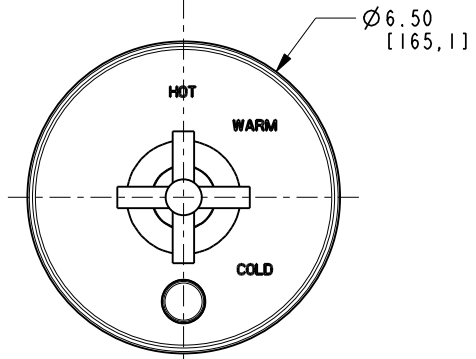
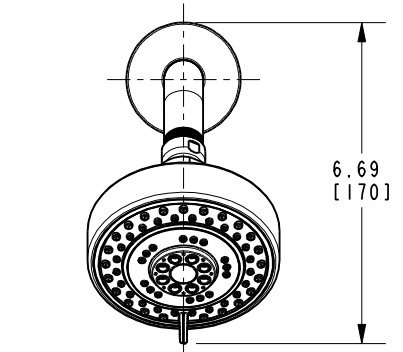
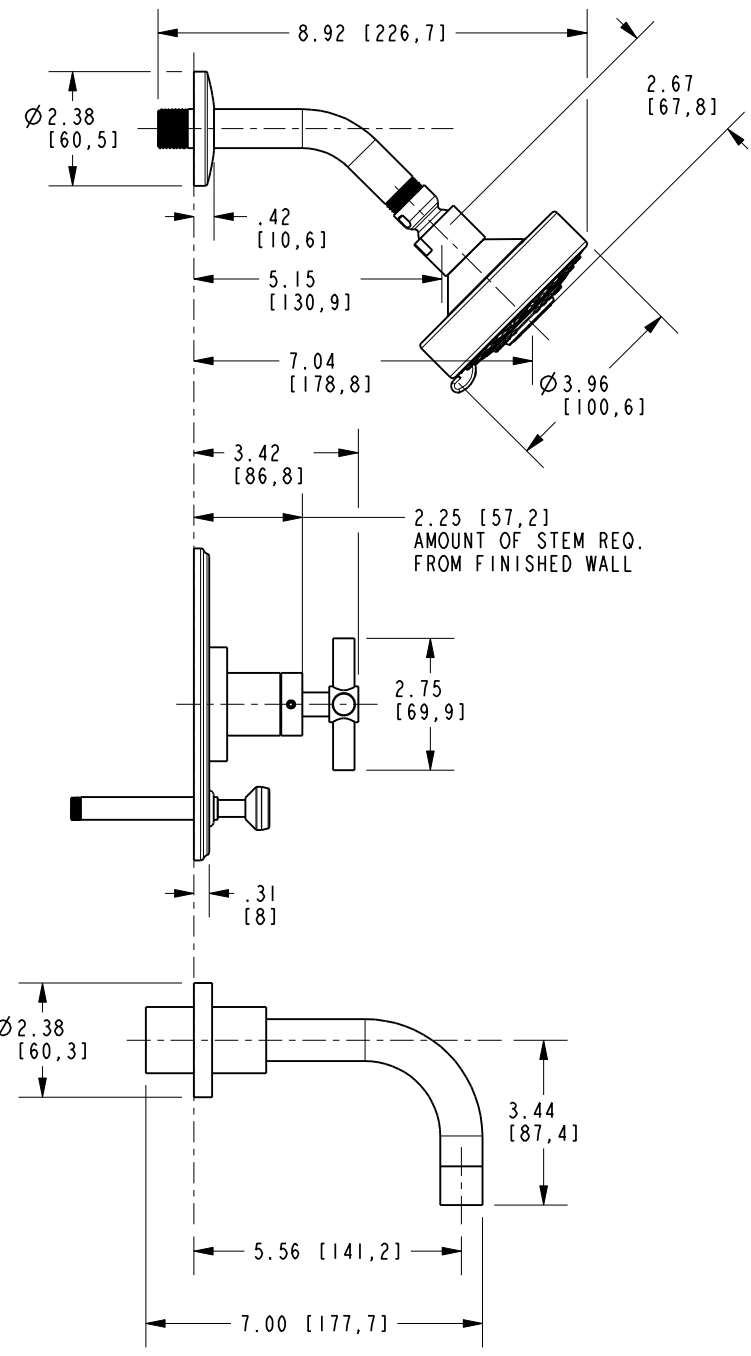

4 3 2 1

BRASSTECH		2001 E. CARNEGIE AVE. SANTA ANA, CA 92705 (949) 417-5207	
DWG NO.	3-992BP	REV	G
SCALE	.250	REF.	-
SHEET 2		OF 2	