

NOTES:

1. TO INSPECT ASSEMBLY, FOLLOW FIRST ARTICLE AND IN PROCESS INSPECTION SHEET.

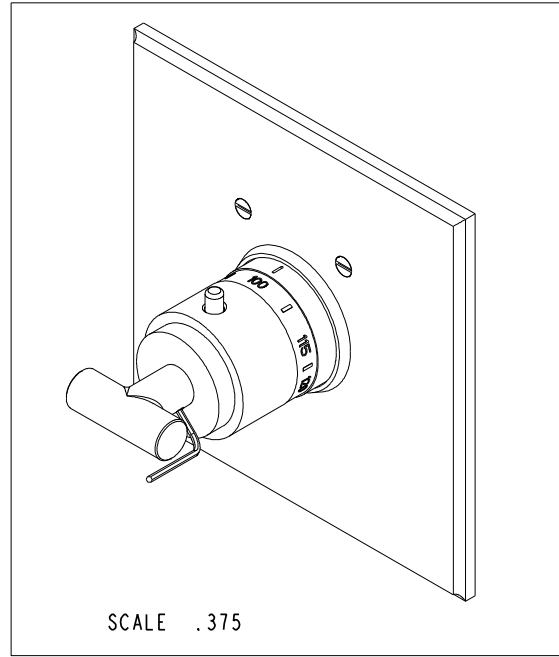

BILL OF MATERIAL (CURRENT LEVEL)				
ITEM	PT/ASSY	DESCRIPTION	TYPE	QTY.
1	2-338	THERMO SQUARE PLATE ASSEMBLY	ASSEMBLY	1
2	11029	SLEEVE - THERMO	PART	1
3	2-339	THERMO BONNET ASM - CONT	ASSEMBLY	1
4	2-262	THERMO HANDLE ASM	ASSEMBLY	1
5	91308	TEMP LIMIT STOP - THERMO	PART	1
6	92113	SCRW, M4 X .7 X 40 PHL FLT HD SS	PART	1
7	10192	HEX KEY TOOL, #8 5/64	PART	1

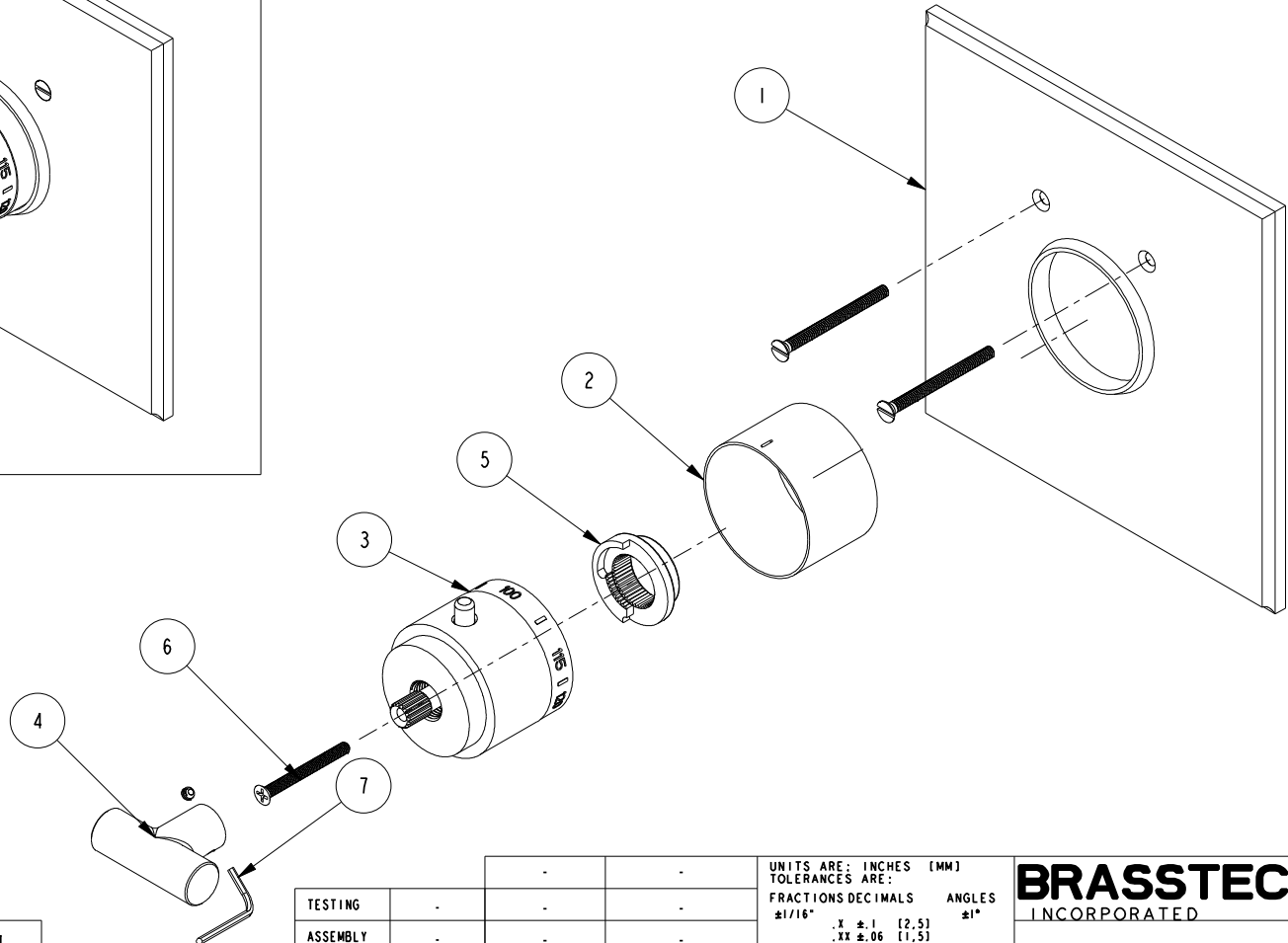

ZONE	REV	DESCRIPTION	DATE	APPROVED
-	C	EN-3961-2	06/23/20	J.M.
-	B	EN-2440	01/23/13	-
-	A	EO-0078	09/16/02	-
-	-	RELEASED	03/01/01	-

COPYRIGHT 2005 BRASSTECH, INC. THESE DRAWINGS AND THE DESIGNS DEPICTED HEREIN ARE THE PROPRIETARY PROPERTY OF BRASSTECH. ANY USE OR REPRODUCTION IS SUBJECT TO THE EXPRESS APPROVAL OF BRASSTECH. UNAUTHORIZED USE IS STRICTLY PROHIBITED. ALL RIGHTS RESERVED.

TESTING	ASSEMBLY	PLATING	POLISHING	MACHINING	TOOLING FIXTURE #	APPLICATION
-	-	-	-	-	-	REMOVE ALL BURRS AND SHARP EDGES
-	-	-	-	-	-	USED ON
-	-	-	-	-	-	APPROVED

UNITS ARE: INCHES [MM]	
FRACTIONS	DECIMALS
±1/16"	.X ±.1 [2.5]
	.XX ±.06 [1.5]
(X.XXX) DENOTES CRITICAL DIMS. ALL THREADS ARE CRITICAL	
DRAWN	03/01/01
CHECKED	03/01/01
APPROVED	03/01/01

BRASSTECH INCORPORATED
 2001 CARNEGIE AVE.
 SANTA ANA, CA 92705
 (949) 417-5207

SQUARE TRIM THERMO

DWG NO. **3-994LTS** REV **C**

SCALE .400 REF. - SHEET 1 OF 3

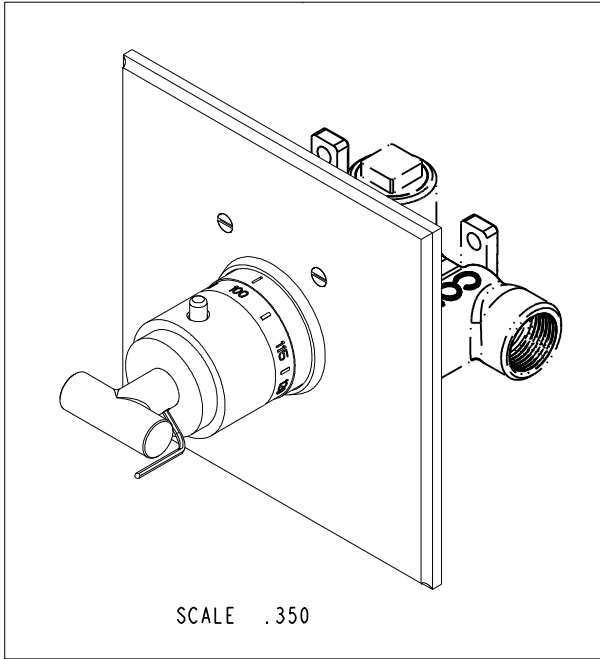

PN: 1-540
SOLD SEPARATELY

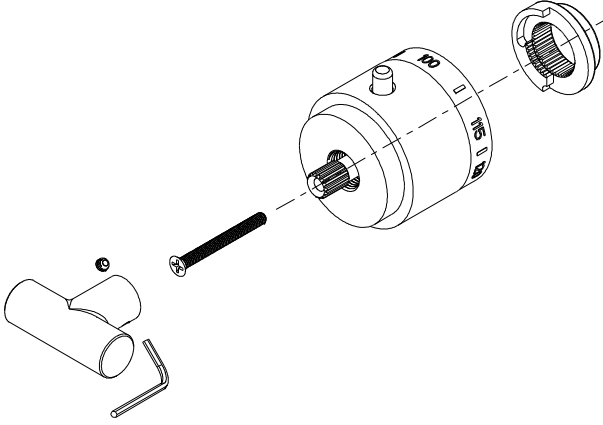
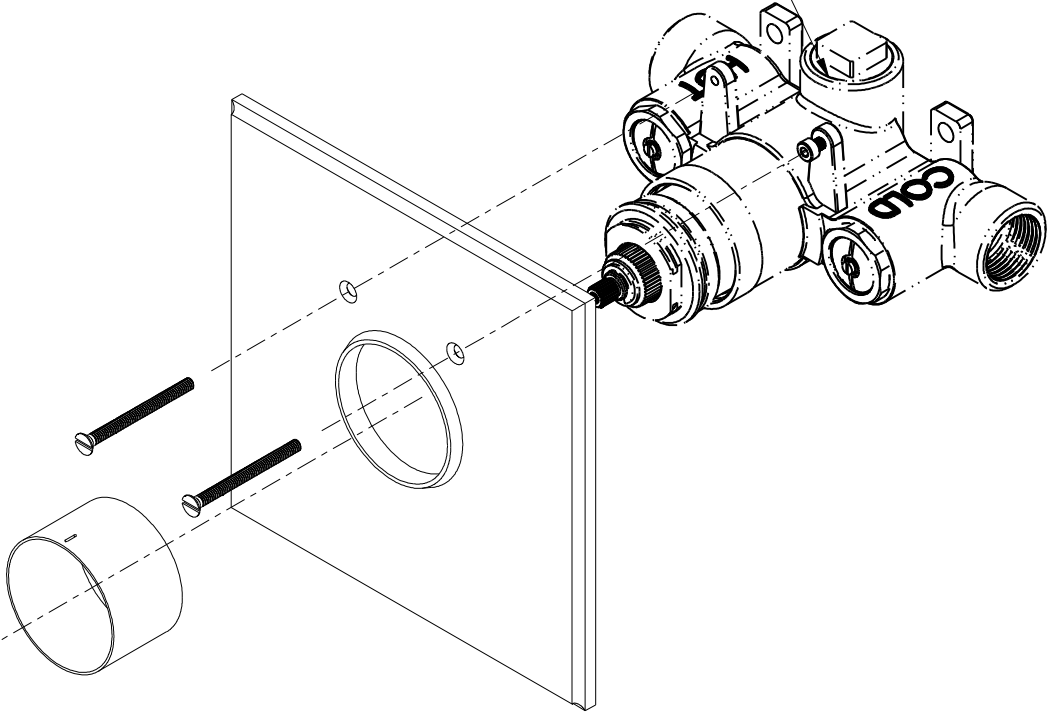

BRASSTECH		2001 CARNEGIE AVE. SANTA ANA, CA 92705 (949) 417-5207	
INCORPORATED			
DWG NO.	3-994LTS	REV	C
SCALE .400	REF. -	SHEET 2	OF 3

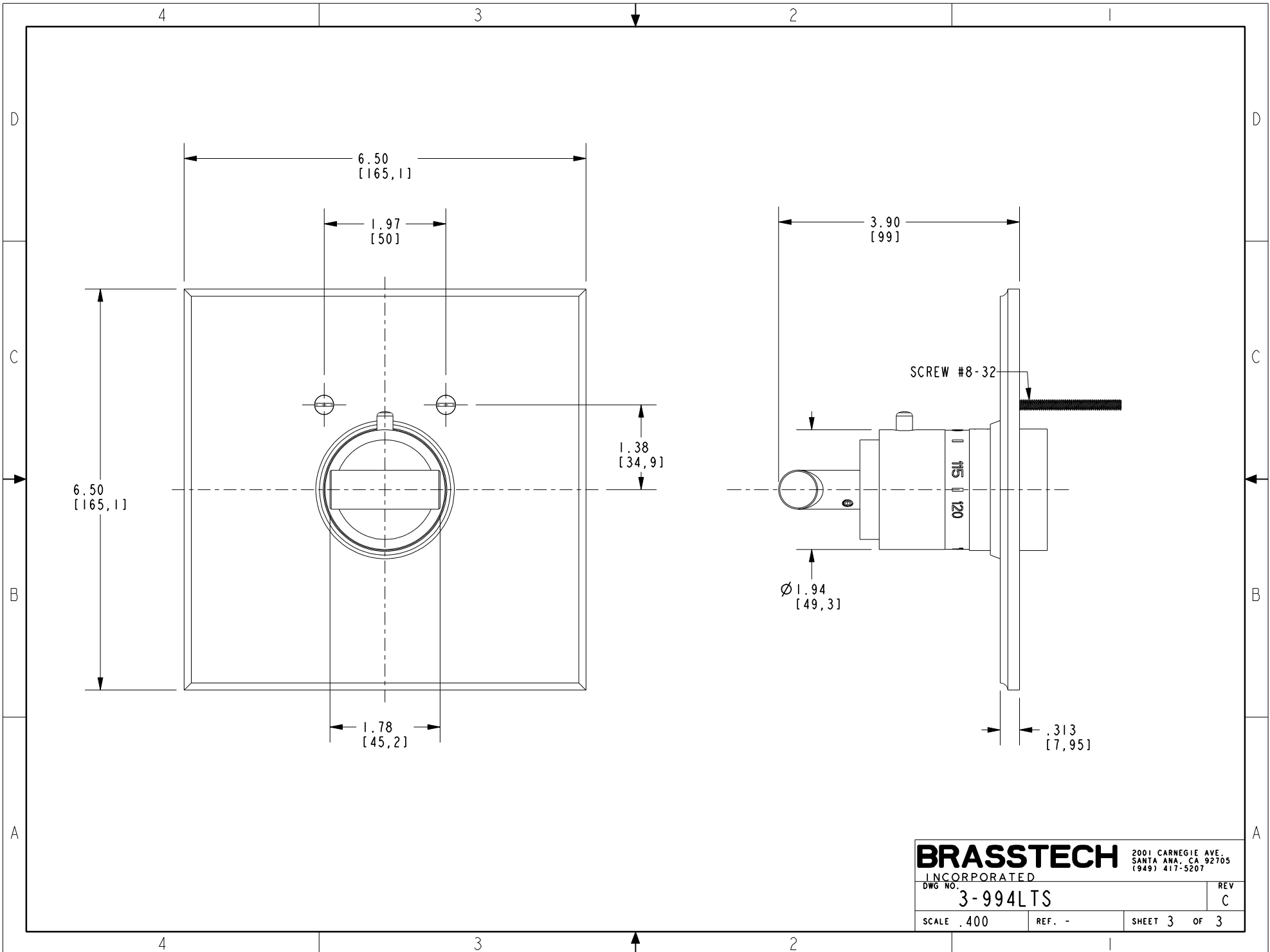

BRASSTECH

2001 CARNEGIE AVE.
SANTA ANA, CA 92705
(949) 417-5207

INCORPORATED

DWG NO.

3-994LTS

REV

C

SCALE .400

REF. -

SHEET 3 OF 3