

NOTES:

1. TO INSPECT ASSEMBLY, FOLLOW FIRST ARTICLE AND IN PROCESS INSPECTION SHEET.

BILL OF MATERIAL (CURRENT LEVEL)

| ITEM | PT/ASSY | DESCRIPTION            | TYPE     | QTY. |
|------|---------|------------------------|----------|------|
| 1    | 1-676   | W/S VALVE INSTALLATION | ASSEMBLY | 1    |
| 2    | 3-420   | W/S SPOUT ASM          | ASSEMBLY | 1    |
| 3    | 3-549   | HANDLE/ ESC ASM        | ASSEMBLY | 2    |
| 4    | 325     | POP UP ASSEMBLY        | ASSEMBLY | 1    |
| 5    | 10288   | 3/16" POP UP ROD       | PART     | 1    |
| 6    | 11738   | POP UP KNOB            | PART     | 1    |
| 7    | 91571   | AERATOR KEY            | PART     | 1    |

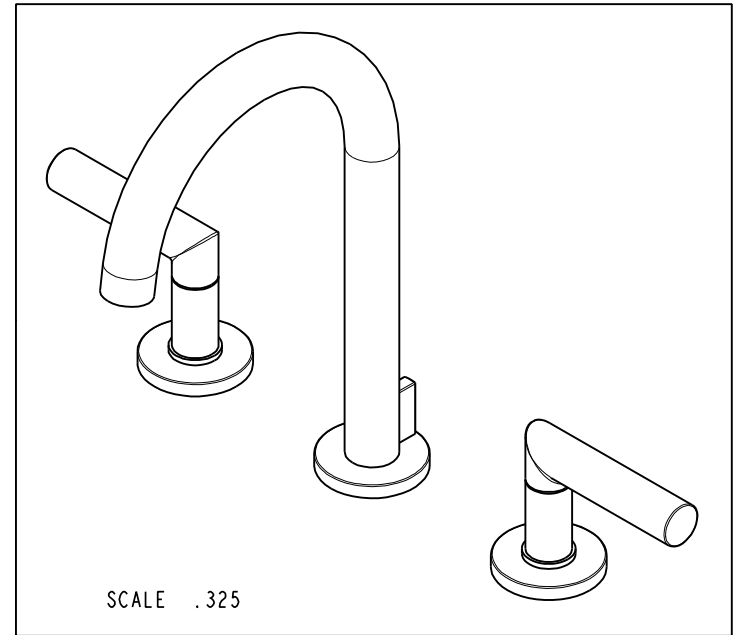
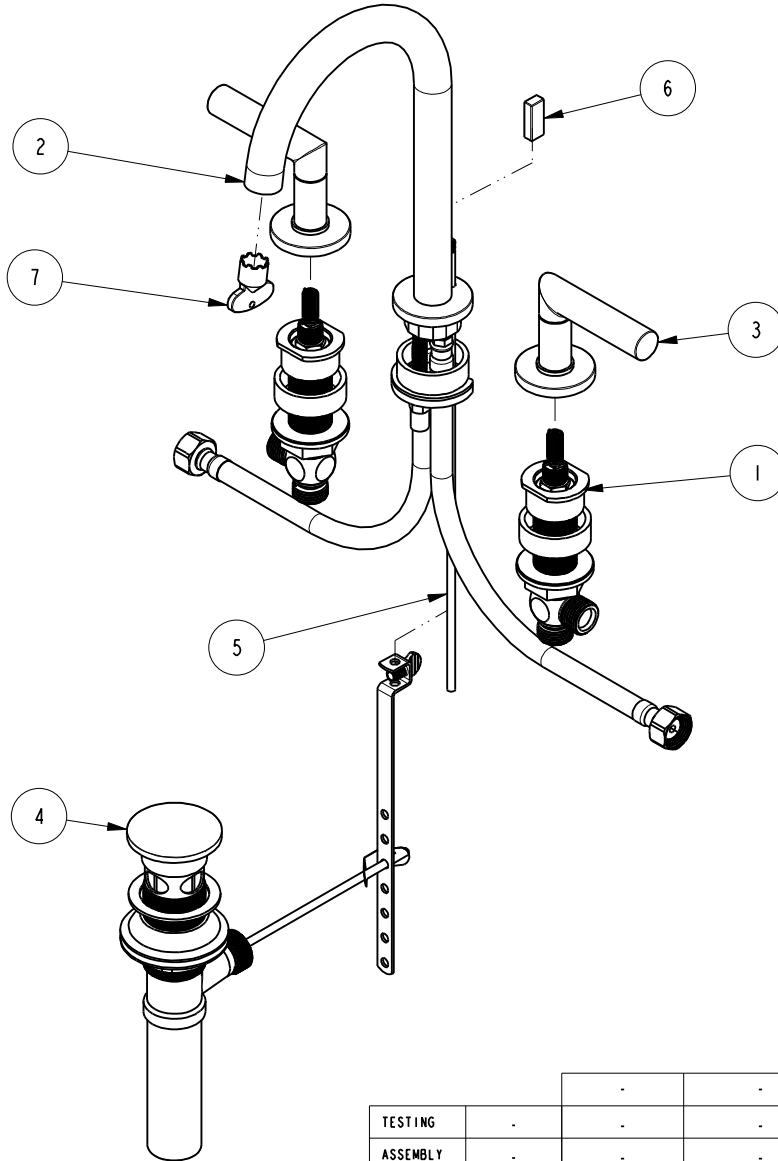

| ZONE | REV | DESCRIPTION | DATE     | APPROVED |
|------|-----|-------------|----------|----------|
| -    | B   | EN-4300m    | 11/06/20 | R.S.     |
| -    | A   | EN-3601     | 05/07/18 | V.V.     |
| -    | -   | EN-3032d    | 07/13/16 | AN       |

COPYRIGHT 2005 BRASSTECH, INC. THESE DRAWINGS AND THE DESIGNS DEPICTED HEREIN ARE THE PROPRIETARY PROPERTY OF BRASSTECH. ANY USE OR REPRODUCTION IS SUBJECT TO THE EXPRESS APPROVAL OF BRASSTECH. UNAUTHORIZED USE IS STRICTLY PROHIBITED. ALL RIGHTS RESERVED.

|                   |                                  |             |         |
|-------------------|----------------------------------|-------------|---------|
| TESTING           | -                                | -           | -       |
| ASSEMBLY          | -                                | -           | -       |
| PLATING           | -                                | -           | -       |
| POLISHING         | -                                | NEXT ASSY   | USED ON |
| MACHINING         | -                                | APPLICATION |         |
| TOOLING FIXTURE # | REMOVE ALL BURRS AND SHARP EDGES |             |         |

UNITS ARE: INCHES [MM]  
TOLERANCES ARE:  
FRACTIONS DECIMALS ANGLES  
±1/16" .X ±.1 [2.5] ±1°  
.XX ±.06 [1.5]

(X.XXX) DENOTES CRITICAL DIMS.  
ALL THREADS ARE CRITICAL

|          |        |          |
|----------|--------|----------|
| DRAWN    | JINSON | 11/06/20 |
| CHECKED  | R.S.   | 11/06/20 |
| APPROVED | R.S.   | 11/06/20 |

**BRASSTECH** 2001 CARNEGIE AVE.  
INCORPORATED SANTA ANA, CA 92705  
(949) 417-5207

W/S LAV FAUCET

|         |      |      |   |
|---------|------|------|---|
| DWG NO. | 3100 | REV  | B |
| SCALE   | .225 | REF. | - |
| SHEET   | 1    | OF   | 2 |

