

NOTES:

1. TO INSPECT ASSEMBLY, FOLLOW FIRST ARTICLE AND IN PROCESS INSPECTION SHEET.

BILL OF MATERIAL (CURRENT LEVEL)

ITEM	PT/ASSY	DESCRIPTION	TYPE	QTY.
1	1-676	W/S VALVE INSTALLATION	ASSEMBLY	1
2	3-402	W/S - MITER SPOUT ASM	ASSEMBLY	1
3	3-549	HANDLE/ ESC ASM	ASSEMBLY	2
4	325	POP UP ASSEMBLY	ASSEMBLY	1
5	10288	3/16" POP UP ROD	PART	1
6	11738	POP UP KNOB	PART	1
7	91571	AERATOR KEY	PART	1

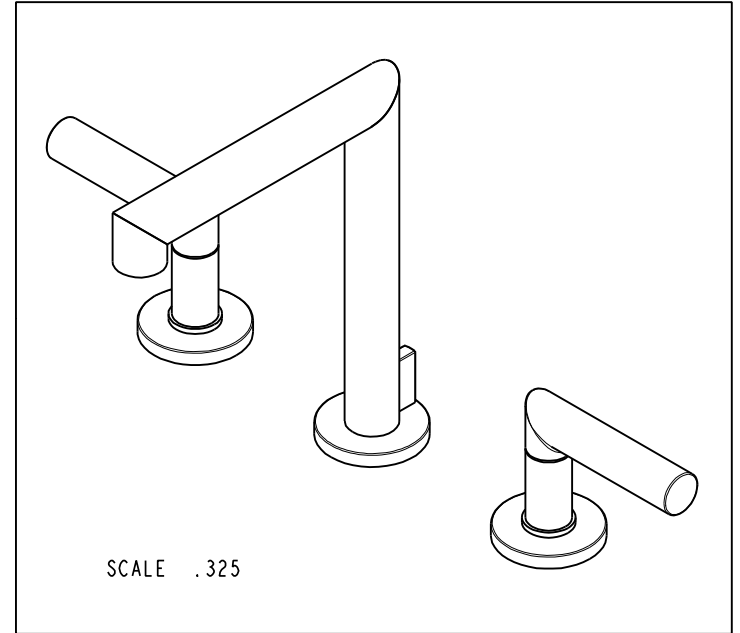
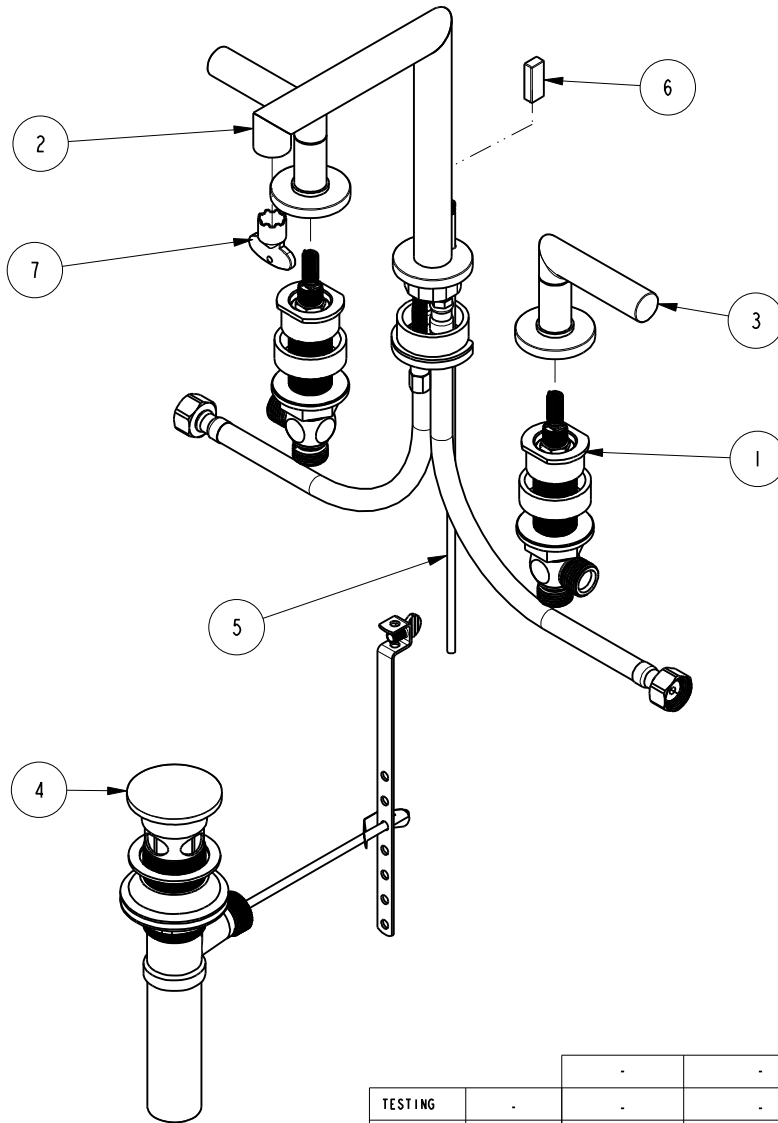

UNITS ARE: INCHES [MM]
 TOLERANCES ARE:
 FRACTIONS DECIMALS ANGLES
 $\pm 1/16"$.X $\pm .1$ [2,5] $\pm 1^\circ$
 .XX $\pm .06$ [1,5]

(X.XXX) DENOTES CRITICAL DIMS.
 ALL THREADS ARE CRITICAL

DRAWN JINSON 11/06/20
 CHECKED R.S. 11/06/20
 APPROVED R.S. 11/06/20

BRASSTECH 2001 CARNEGIE AVE.
 INCORPORATED SANTA ANA, CA 92705
 (949) 417-5207

W/S LAV FAUCET

DWG NO. 3120 REV B
 SCALE .225 REF. - SHEET 1 OF 2

TESTING	-	-	-
ASSEMBLY	-	-	-
PLATING	-	-	-
POLISHING	-	NEXT ASSY	USED ON
MACHINING	-	APPLICATION	
TOOLING FIXTURE #	REMOVE ALL BURRS AND SHARP EDGES		

ZONE	REV	DESCRIPTION	DATE	APPROVED
-	B	EN-4300m	11/06/20	R.S.
-	A	EN-3601	05/07/18	V.V.
-	-	EN-3032d	07/13/16	AN

COPYRIGHT 2005 BRASSTECH, INC.
 THESE DRAWINGS AND THE DESIGNS
 DEPICTED HEREIN ARE THE PROPRIETARY
 PROPERTY OF BRASSTECH. ANY USE
 OR REPRODUCTION IS SUBJECT TO
 THE EXPRESS APPROVAL OF BRASSTECH.
 UNAUTHORIZED USE IS STRICTLY
 PROHIBITED. ALL RIGHTS RESERVED.

