

NOTES:

(NI) 1. FIT / FORM / FUNCTION SHALL FOLLOW PS-E.008.

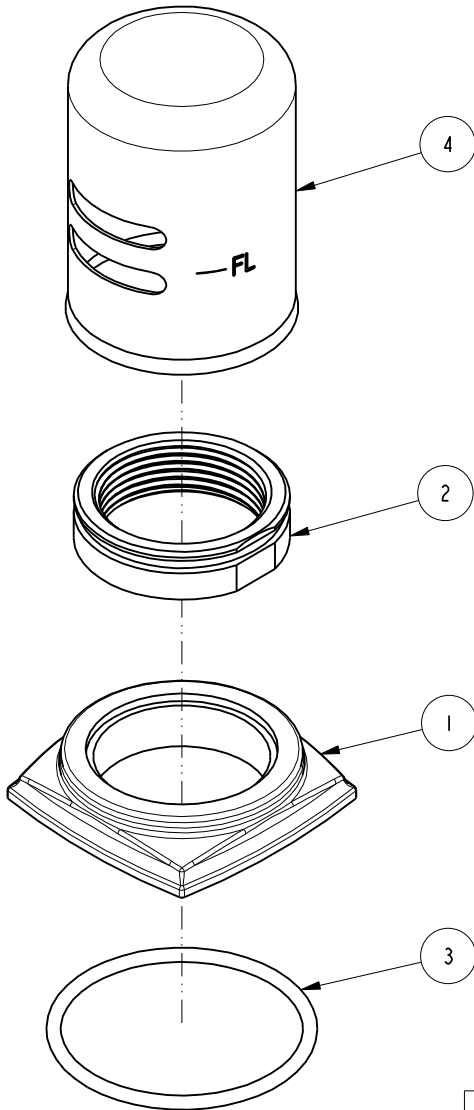

BILL OF MATERIAL (CURRENT LEVEL)

ITEM	PT/ASSY	DESCRIPTION	TYPE	QTY.
1	12707	ESCUTCHEON	PART	1
2	20-244	AIR GAP ADAPTER ASM	ASSEMBLY	1
3	91762	O-RING, #2-132, EP, 50 DURO - GREY	PART	1
4	50688	AIR GAP CAP	PART	1

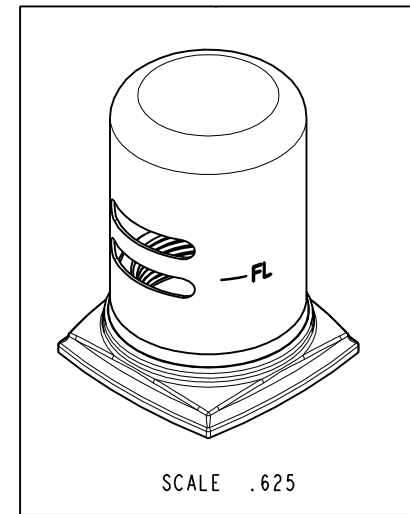

ZONE	REV	DESCRIPTION	DATE	APPROVED
-	A	EN-3722	02/08/19	C.G.
-	-	EN-3229	03/14/17	J.M.

COPYRIGHT 2005 BRASSTECH, INC. THESE DRAWINGS AND THE DESIGNS DEPICTED HEREIN ARE THE PROPRIETARY PROPERTY OF BRASSTECH. ANY USE OR REPRODUCTION IS SUBJECT TO THE EXPRESS APPROVAL OF BRASSTECH. UNAUTHORIZED USE IS STRICTLY PROHIBITED. ALL RIGHTS RESERVED.

TESTING	-	-	-
ASSEMBLY	-	-	-
PLATING	-	3160-5711	3160-5711
POLISHING	-	NEXT ASSY	USED ON
MACHINING	-	APPLICATION	
TOOLING FIXTURE #	REMOVE ALL BURRS AND SHARP EDGES		

UNITS ARE: INCHES [MM]		
TOLERANCES ARE:		
FRACTIONS	DECIMALS	ANGLES
±1/16"	.X ±.1 [2,5]	±1°
	.XX ±.06 [1,5]	
(X.XXX) DENOTES CRITICAL DIMS. ALL THREADS ARE CRITICAL		
DRAWN	JINSON	02/08/19
CHECKED	C.G.	02/08/19
APPROVED	C.G.	02/08/19

BRASSTECH 2001 CARNEGIE AVE.
INCORPORATED SANTA ANA, CA 92705
(949) 417-5207

AIR CAP ASM

DWG NO.	3160-5751	REV	A
SCALE	.725	REF.	-
SHEET	1	OF	2

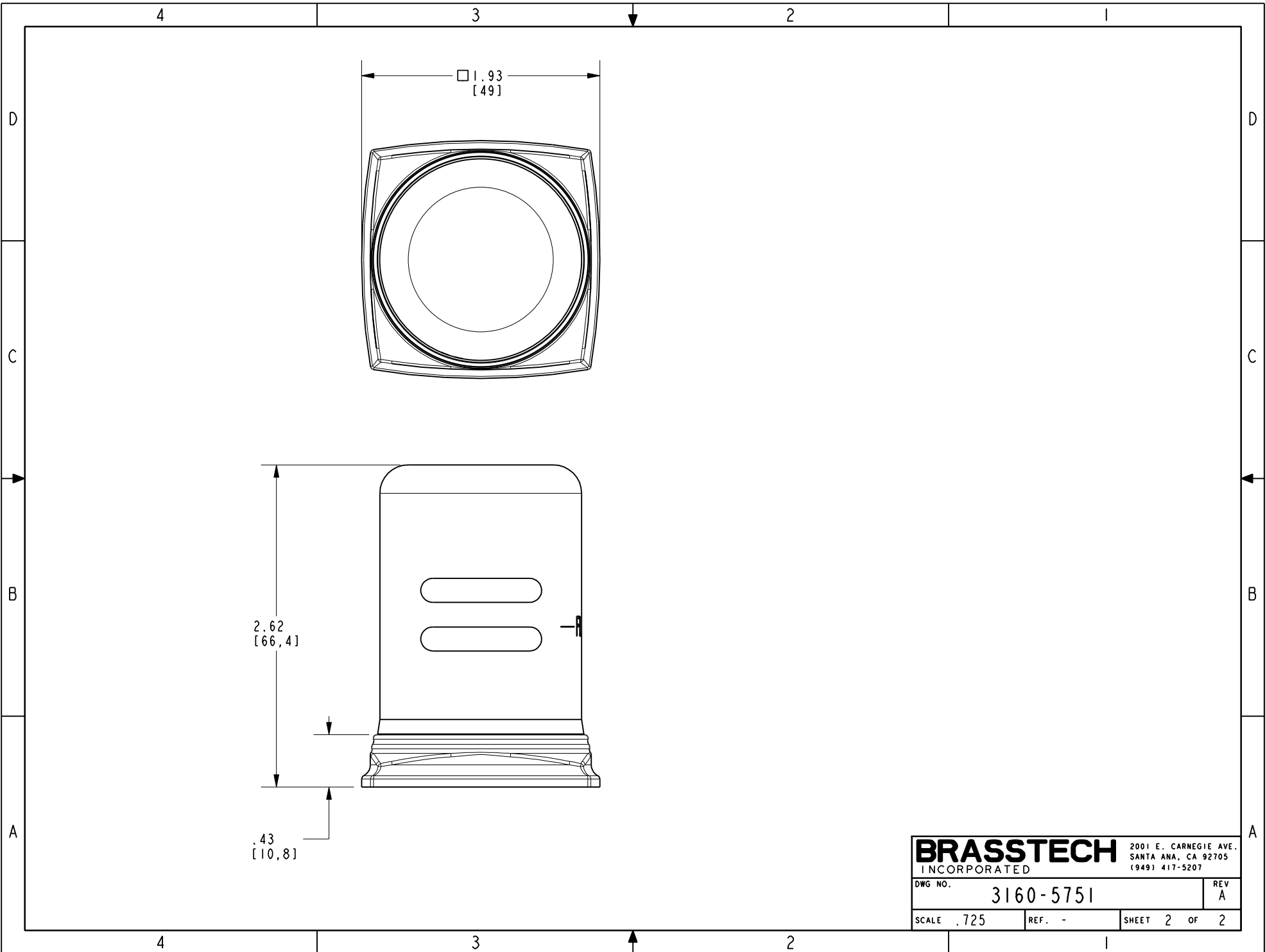

BRASSTECH 2001 E. CARNEGIE AVE.
 INCORPORATED SANTA ANA, CA 92705
 (949) 417-5207

DWG NO.	3160-5751	REV	A
SCALE	.725	REF.	-
SHEET 2		OF 2	