

NOTES:

1. TO INSPECT ASSEMBLY, FOLLOW FIRST ARTICLE AND IN PROCESS INSPECTION SHEET.

- 2 APPLY LOCTITE 680.
- 3 CUT AND SHORTEN O-RING BY .13" TO .20" IN LENGTH BEFORE INSTALLING.
- 4 SLIT O-RING BEFORE INSTALLING.
- 5 APPLY LOCTITE 242.
- 6 CONNECT WHITE AND RED TUBINGS TOGETHER AND WATER TEST WHOLE UNIT.
- 7 BAG 92194 IN A SEPARATE BAG.
- 8 REWORK CARTRIDGE ASSY IF THE HANDLE DOES NOT RETURN TO THE 'OFF' POSITION AUTOMATICALLY AFTER WATER TESTING.
- 9 INSTALLATION TORQUE: 8-14 LB-FT.
- 10 INSTALLATION TORQUE: 78 LB-IN +/- 6 LB-IN.
- 11 LUBRICATE SPRING WITH DOW CORNING 111 SILICONE COMPOUND.
- 12 APPLY LIGHT FILM OF DOW CORNING 111 SILICONE COMPOUND.

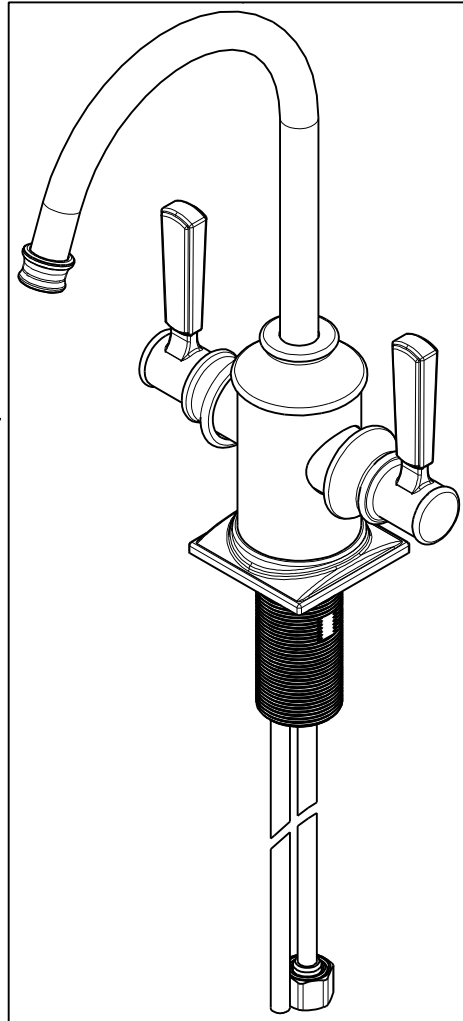

BILL OF MATERIAL (CURRENT LEVEL)

| ITEM | PT/ASSY | DESCRIPTION | TYPE | QTY. |
|------|---------|---|----------|------|
| 1 | 1-134 | CARTR 3/8 HOT 1/4 TR | PART | 1 |
| 2 | 1-393 | 1-1/8 18 UNEF MOUNTING KIT | ASSEMBLY | 1 |
| 3 | 1-431 | RED SUPPLY LINE | ASSEMBLY | 1 |
| 4 | 1-432 | BLUE SUPPLY LINE | ASSEMBLY | 1 |
| 5 | 1-433 | GREY SUPPLY LINE | ASSEMBLY | 1 |
| 6 | 5-061 | ADAPTER/CARTRIDGE ASSY | ASSEMBLY | 1 |
| 7 | 20-248 | BASE RING ASM | ASSEMBLY | 1 |
| 8 | 20-288 | HANDLE HUB ASM | ASSEMBLY | 2 |
| 9 | 11733 | SHELL, SPOUT, WATER DISP | PART | 1 |
| 10 | 12512 | BONNET | PART | 2 |
| 11 | 12703 | COLLAR | PART | 1 |
| 12 | 12750 | ADAPTER | PART | 1 |
| 13 | 13070 | RETAINER PLATE | PART | 1 |
| 14 | 13287 | WATER DISP. BODY H/C (CONT) | PART | 1 |
| 15 | 13289 | NIPPLE | PART | 1 |
| 16 | 50713 | SPOUT, WATER DISP. (TRAD.) | PART | 1 |
| 17 | 50714 | WATER DISP. CAR.T HOLDER | PART | 2 |
| 18 | 50717 | WATER DISP SPOUT RETAINER | PART | 1 |
| 19 | 91017 | O-RING, #2- 012, EPDM, 65-75 DURO, NSF 61 | PART | 2 |
| 20 | 91023 | O-RING, #2- 019, EPDM, 65-75 DURO, NSF 61 | PART | 1 |
| 21 | 91382 | O-RING, #2- 012, TEFLON, | PART | 1 |
| 23 | 91383 | O-RING, #2- 014, TEFLON, NSF 61 | PART | 1 |
| 24 | 91424 | WSHR, .81 ID X .93 OD X .045 THK, FLT, PLST | PART | 2 |
| 25 | 92016 | SCRW, 10-24 X 3/4 SKT HD FLT PT SS | PART | 1 |
| 26 | 92194 | COUPLING, 3/8" X 1/4" | PART | 1 |
| 27 | 92862 | SCRW, M4 X 18 SKT FLT HD SS | PART | 1 |
| 28 | 98043 | TAG LABEL, HOT WATER WARNING | PART | 1 |

| - | F | EN-4300jj | 04/12/21 | R.S. |
|------|-----|-------------|----------|----------|
| - | E | EN-3634A | 11/20/19 | C.G. |
| - | D | EN-3941 | 08/28/19 | C.G. |
| - | C | EN-3862 | 05/08/19 | C.G. |
| - | B | EN-3558a | 01/02/19 | V.V. |
| - | A | EN-3693 | 08/29/18 | J.M. |
| - | - | EN-3076 | 06/08/17 | J.M. |
| ZONE | REV | DESCRIPTION | DATE | APPROVED |

COPYRIGHT 2005 BRASSTECH, INC. THESE DRAWINGS AND THE DESIGNS DEPICTED HEREIN ARE THE PROPRIETARY PROPERTY OF BRASSTECH. ANY USE OR REPRODUCTION IS SUBJECT TO THE EXPRESS APPROVAL OF BRASSTECH. UNAUTHORIZED USE IS STRICTLY PROHIBITED. ALL RIGHTS RESERVED.

| | | | |
|-------------------|----------------------------------|-------------|---------|
| TESTING | - | - | - |
| ASSEMBLY | - | - | - |
| PLATING | - | - | - |
| POLISHING | - | NEXT ASSY | USED ON |
| MACHINING | - | APPLICATION | |
| TOOLING FIXTURE # | REMOVE ALL BURRS AND SHARP EDGES | | |

UNITS ARE: INCHES [MM]
TOLERANCES ARE:
FRACTIONS DECIMALS ANGLES
±1/16" .X ±.1 [2.5] ±1°
.XX ±.06 [1.5]

(X.XXX) DENOTES CRITICAL DIMS.
ALL THREADS ARE CRITICAL

| | | |
|----------|--------|----------|
| DRAWN | JINSON | 04/12/21 |
| CHECKED | R.S. | 04/12/21 |
| APPROVED | R.S. | 04/12/21 |

BRASSTECH 2001 CARNEGIE AVE.
INCORPORATED SANTA ANA, CA 92705
(949) 417-5207

WATER DISPENSER - HOT & COLD

DWG NO. **3170-5603** REV **F**

SCALE .400 REF. - SHEET 1 OF 3

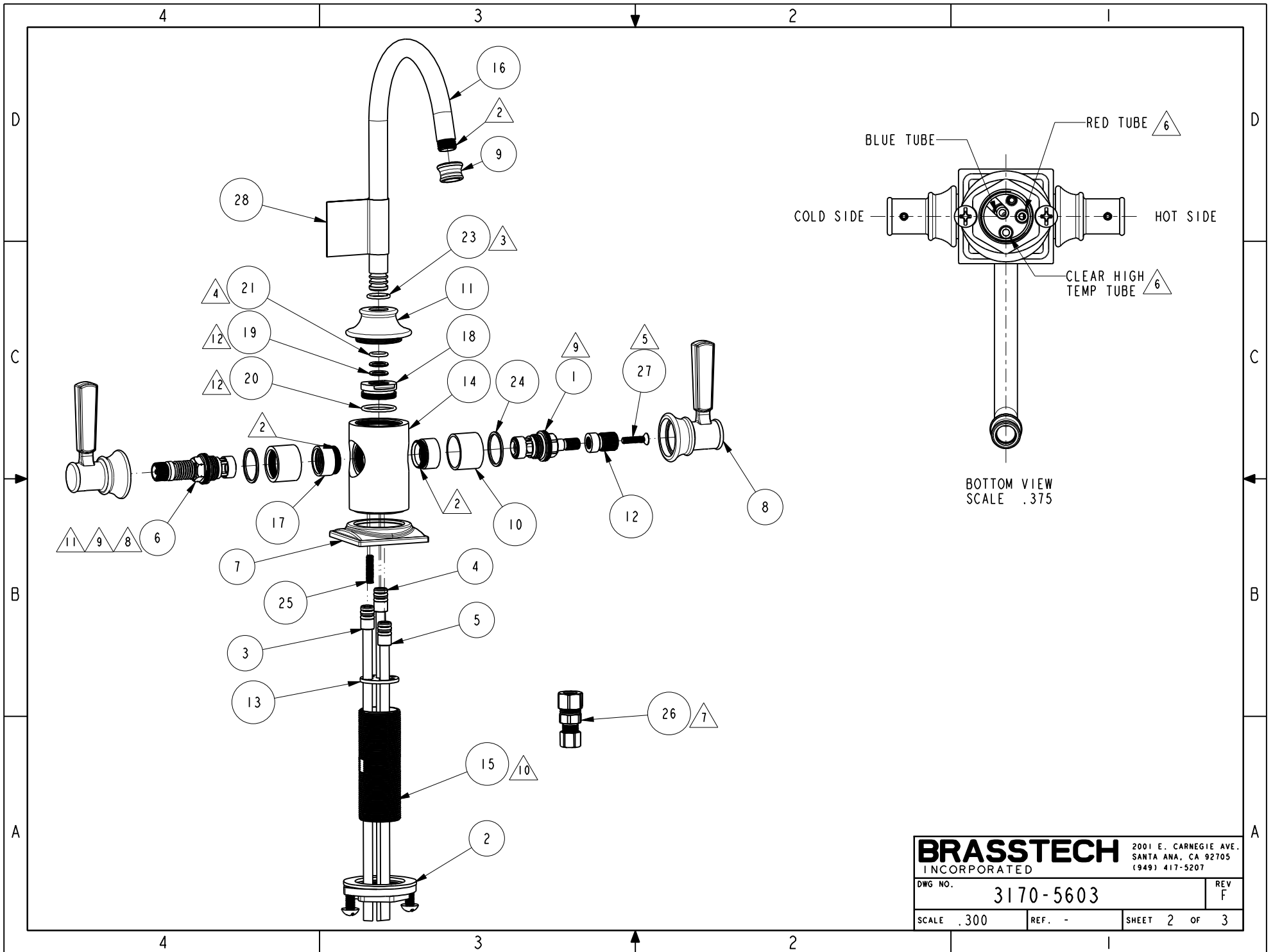

| | | |
|------------------|-----------|--|
| BRASSTECH | | 2001 E. CARNEGIE AVE. SANTA ANA, CA 92705 (949) 417-5207 |
| DWG NO. | 3170-5603 | REV F |
| SCALE .300 | REF. - | SHEET 2 OF 3 |

