

NOTES:

- 1. TO INSPECT ASSEMBLY, FOLLOW FIRST ARTICLE AND IN PROCESS INSPECTION SHEET.
- 2. PACK THESE ITEMS IN A PLASTIC BAG.
- 3. HANDLE IN CLOSE POSITION.
- 4. INSTALLATION TORQUE 11-14 LB-FT.
- 5. INSTALLATION TORQUE 4-6 LB-FT.
- 6. APPLY LOCTITE 680.
- 7. APPLY LOCTITE 242
- 8. SWIVEL CONNECTION SHALL NOT HAVE NOTICEABLE WOBBLINESS AFTER ASSEMBLY.

BILL OF MATERIAL (CURRENT LEVEL)

ITEM	PT/ASSY	DESCRIPTION	TYPE	QTY.
1	11330	VALVE BODY, WALL-END	PART	1
2	11309	FLANGE, MOUNTING	PART	1
3	92223	SCRW, #8 X 2-1/2 PHL FLT HD SS	PART	4
4	92231	SCRW, 1/4-20 X 1/4 SKT HD CUP PT SS	PART	1
5	20-255	BASE ASSEMBLY	ASSEMBLY	1
6	2-553	LOWER ARM ASM, CONTEMP	ASSEMBLY	1
7	2-552	UPPER ARM ASM, CONTEMP	ASSEMBLY	1
8	1-326	W/S CARTRIDGE FRICTION - HOT	PART	1
9	12750	ADAPTER	PART	2
10	1-437	CARTR 3/8 HOT 1/4 TR	PART	1
11	12712	HANDLE HUB	PART	2
12	92862	SCRW, M4 X 18 SKT FLT HD SS	PART	2
13	20-283	CAP ASM	ASSEMBLY	2

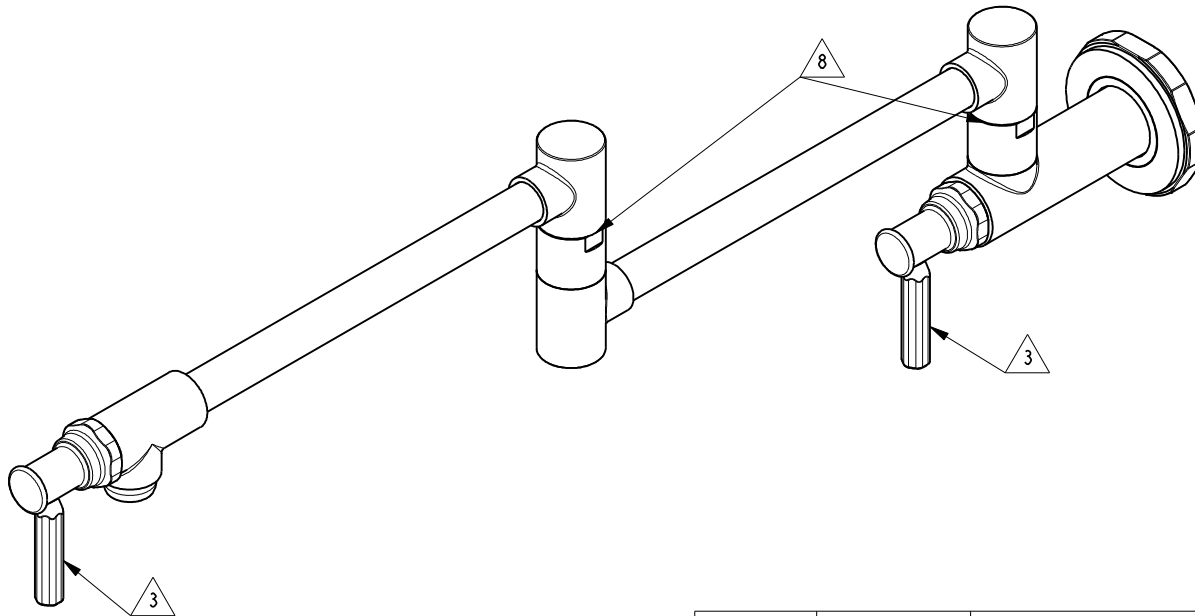

ZONE	REV	DESCRIPTION	DATE	APPROVED
-	D	EN-4300q	11/20/20	R.S.
-	C	EN-4112	03/24/20	J.M.
-	B	EN-3756	11/26/18	C.G.
-	A	EN-3693	08/28/18	J.M.
-	-	EN-3229	06/16/17	J.M.

COPYRIGHT 2005 BRASSTECH, INC. THESE DRAWINGS AND THE DESIGNS DEPICTED HEREIN ARE THE PROPRIETARY PROPERTY OF BRASSTECH. ANY USE OR REPRODUCTION IS SUBJECT TO THE EXPRESS APPROVAL OF BRASSTECH. UNAUTHORIZED USE IS STRICTLY PROHIBITED. ALL RIGHTS RESERVED.

TESTING	ASSEMBLY	PLATING	POLISHING	MACHINING
-	-	-	-	-
TOOLING FIXTURE #		REMOVE ALL BURRS AND SHARP EDGES		

UNITS ARE: INCHES [MM]		TOLERANCES ARE:	
FRACTIONS DECIMALS	ANGLES	±1°	
±1/16"	.X ±.1 [2,5]	.XX ±.06 [1,5]	
(X.XXX) DENOTES CRITICAL DIMS. ALL THREADS ARE CRITICAL			
DRAWN	JINSON	11/20/20	
CHECKED	R.S.	11/20/20	
APPROVED	R.S.	11/20/20	

BRASSTECH		2001 CARNEGIE AVE. SANTA ANA, CA 92705 (949) 417-5207	
INCORPORATED		POT FILLER	
DWG NO. 3190-5503		REV D	
SCALE .300	REF. -	SHEET 1 OF 3	

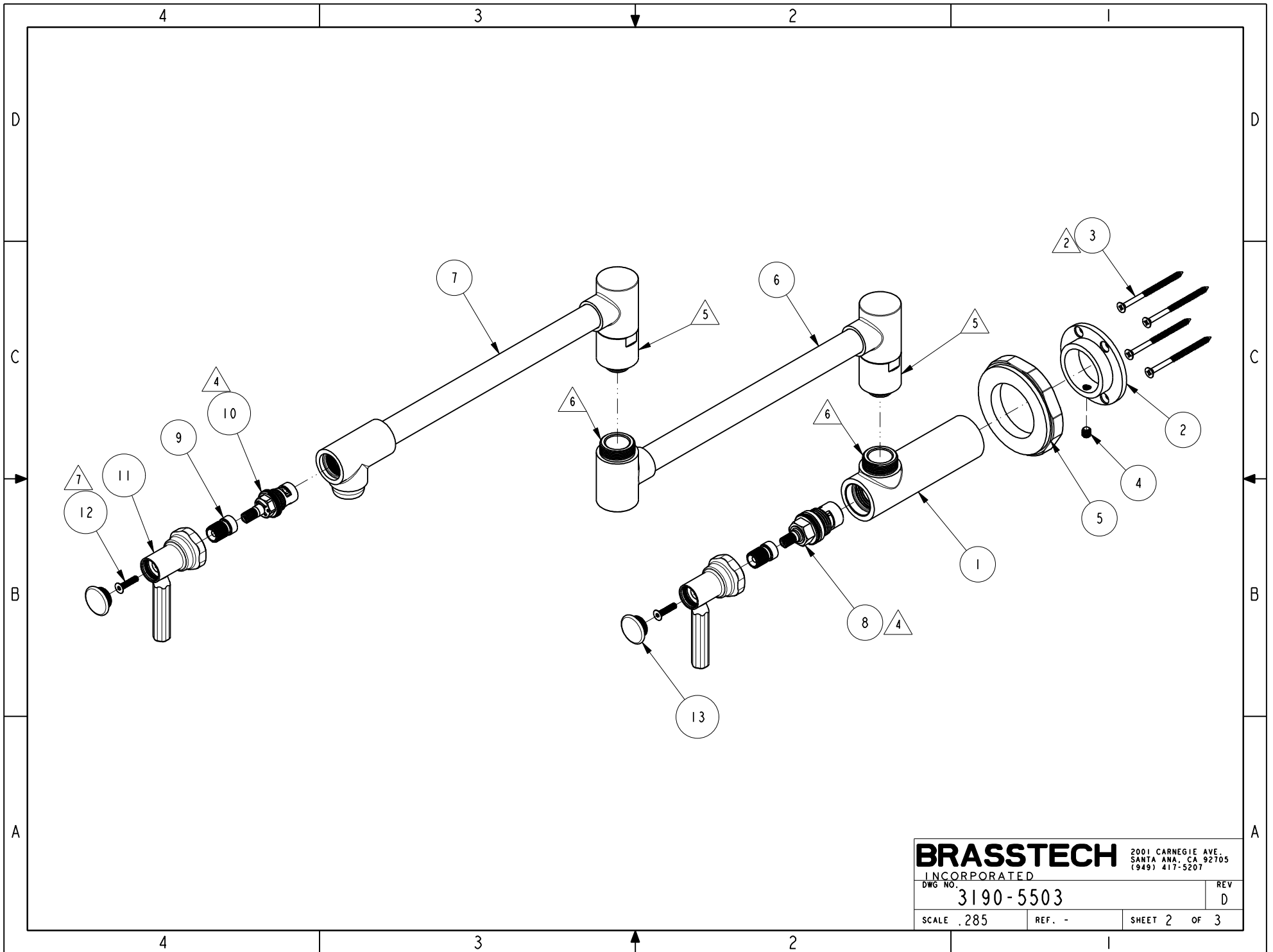

BRASSTECH 2001 CARNEGIE AVE.
 INCORPORATED SANTA ANA, CA 92705
 (949) 417-5207

DWG NO.	3190-5503	REV	D
SCALE	.285	REF.	-
SHEET 2		OF 3	

