

NOTES:

1. TO INSPECT ASSEMBLY, FOLLOW FIRST ARTICLE AND IN PROCESS INSPECTION SHEET.

2 APPLY LOCTITE 680.

3 CUT AND SHORTEN O-RING BY .13" TO .20" IN LENGTH BEFORE INSTALLING.

4 SLIT O-RING BEFORE INSTALLING.

5 APPLY LOCTITE 242.

6. WATER TEST WHOLE UNIT.

7 BAG 5-007 IN A SEPARATE BAG.

8 INSTALLATION TORQUE: 8-14 LB-FT.

9 APPLY LIGHT FILM OF DOW CORNING 111 SILICONE COMPOUND.

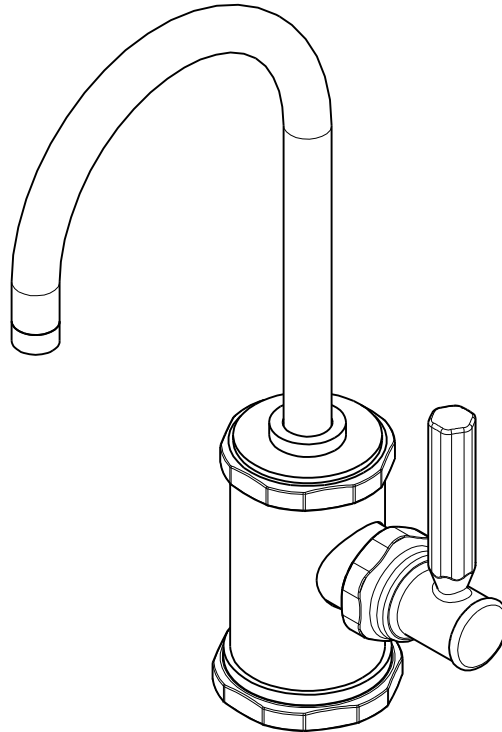

BILL OF MATERIAL (CURRENT LEVEL)

ITEM	PT/ASSY	DESCRIPTION	TYPE	QTY.
1	20-294	ESCUTCHEON ASM	ASSEMBLY	1
2	13605	WATER DISP. BODY COLD (CONT)	PART	1
3	13678	BODY CAP	PART	1
4	91023	O-RING, #2- 019, EPDM, 65-75 DURO, NSF 61	PART	1
5	5-052	SPOUT ASM	ASSEMBLY	1
6	91382	O-RING, #2- 012, TEFLON,	PART	1
7	91017	O-RING #2-012	PART	2
8	91383	O-RING, #2- 014, TEFLON, NSF 61	PART	1
9	12512	BONNET	PART	1
10	1-134	CARTR 3/8 HOT 1/4 TR	PART	1
11	12750	ADAPTER	PART	1
12	50760	NIPPLE WATER DISP	PART	1
13	5-007	1/4 COMP KIT	ASSEMBLY	1
14	10661	MOUNTING STUD	PART	1
15	91063	MOUNTING CRESCENT GASKET	PART	1
16	10514	MOUNTING CRESCENT	PART	1
17	10516	MOUNTING NUT	PART	1
18	92862	SCRW, M4 X 18 SKT FLT HD SS	PART	1
19	20-292	HANDLE HUB ASM	ASSEMBLY	1
20	91424	WSHR, .81 ID X .93 OD X .045 THK, FLT, PLST	PART	1

ZONE	REV	DESCRIPTION	DATE	APPROVED
-	D	EN-4187	10/25/22	J.M.
-	C	EN-4300jj	07/22/21	R.S.
-	B	EN-3941	08/28/19	C.G.
-	A	EN-3693	08/29/18	J.M.
-	-	EN-3229	08/21/17	J.M.

COPYRIGHT 2005 BRASSTECH, INC. THESE DRAWINGS AND THE DESIGNS DEPICTED HEREIN ARE THE PROPRIETARY PROPERTY OF BRASSTECH. ANY USE OR REPRODUCTION IS SUBJECT TO THE EXPRESS APPROVAL OF BRASSTECH. UNAUTHORIZED USE IS STRICTLY PROHIBITED. ALL RIGHTS RESERVED.

TESTING	-	-	-
ASSEMBLY	-	-	-
PLATING	-	-	-
POLISHING	-	NEXT ASSY	USED ON
MACHINING	-	APPLICATION	
TOOLING FIXTURE #	REMOVE ALL BURRS AND SHARP EDGES		

UNITS ARE: INCHES [MM]  
TOLERANCES ARE:  
FRACTIONS DECIMALS ANGLES  
±1/16" .X ±.1 [2.5] ±1°  
.XX ±.06 [1.5]

(X.XXX) DENOTES CRITICAL DIMS.  
ALL THREADS ARE CRITICAL

DRAWN	JINSON	10/25/22
CHECKED	G.B.	10/25/22
APPROVED	J.M.	10/25/22

**BRASSTECH** 2001 CARNEGIE AVE. SANTA ANA, CA 92705 (949) 417-5207  
INCORPORATED

**WATER DISPENSER - COLD**

DWG NO. 3190-5623	REV D
SCALE .500	REF. -
SHEET 1	OF 3

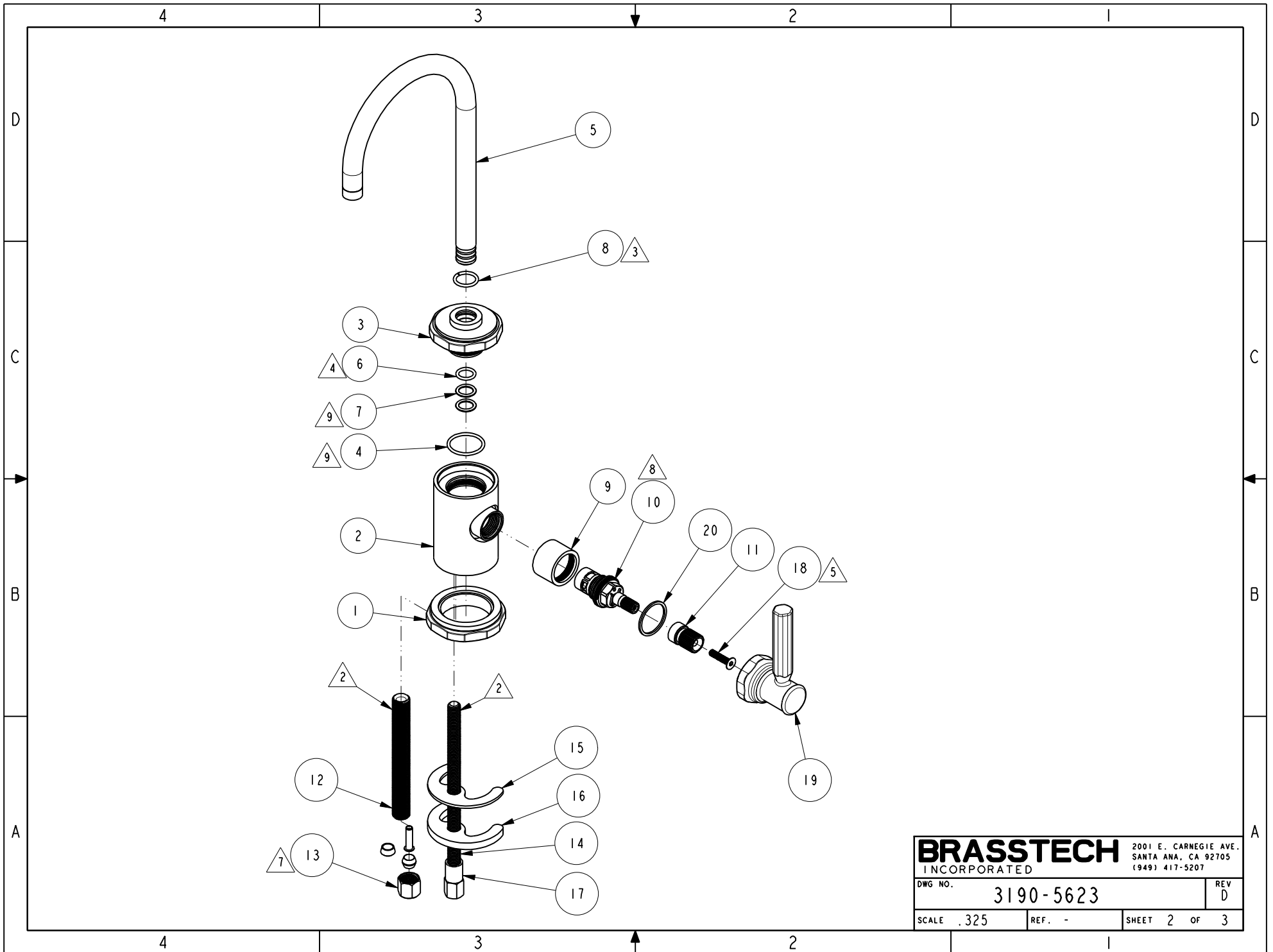

<b>BRASSTECH</b>		2001 E. CARNEGIE AVE. SANTA ANA, CA 92705 (949) 417-5207
DWG NO.	3190-5623	REV D
SCALE .325	REF. -	SHEET 2 OF 3

