

NOTES:

1. TO INSPECT ASSEMBLY, FOLLOW FIRST ARTICLE AND IN PROCESS INSPECTION SHEET.

BILL OF MATERIAL (CURRENT LEVEL)

ITEM	PT/ASSY	DESCRIPTION	TYPE	QTY.
1	20-382	AIR SWITCH, CONTEMP	ASSEMBLY	1
2	91321	TUBING - PVC BLK (6ft)	PART	1
3	50648	ELECTRIC PLUG SWITCH	PART	1

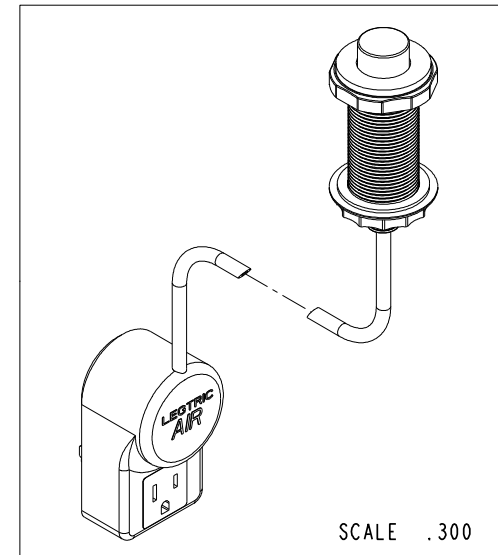
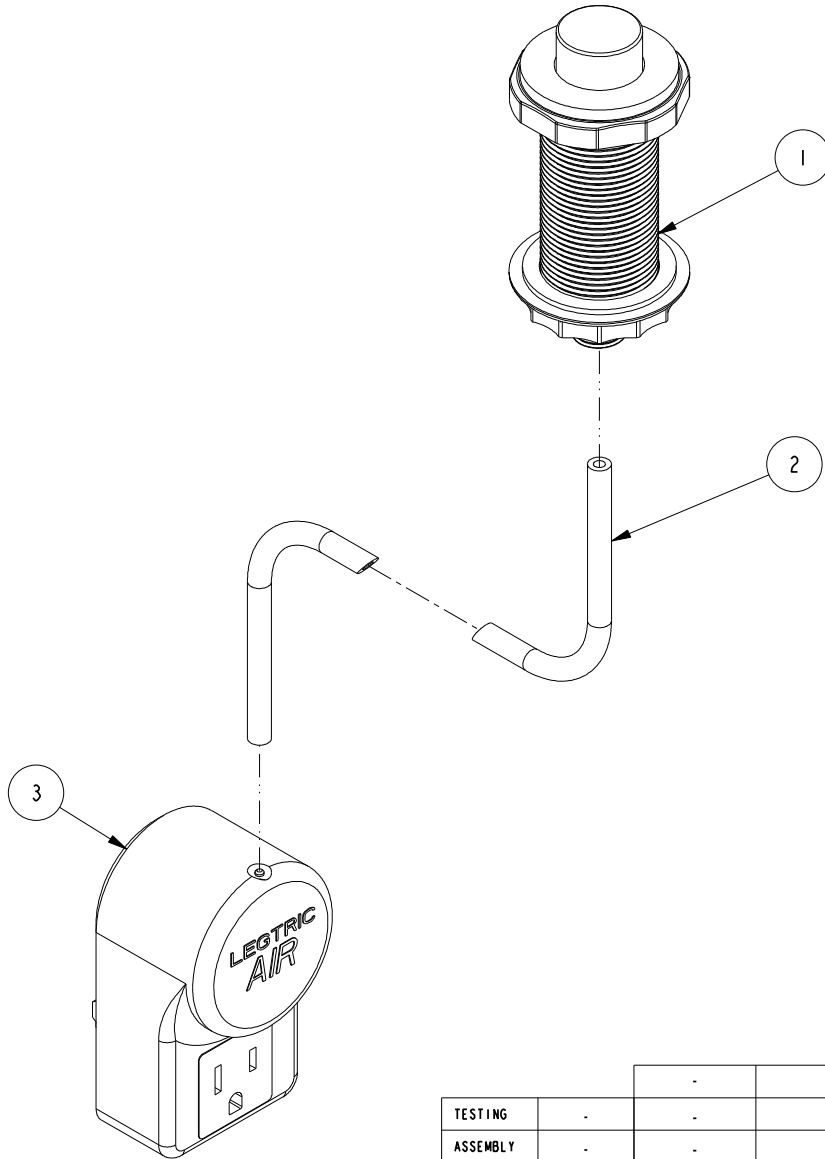

TESTING	-	-	-
ASSEMBLY	-	-	-
PLATING	-	-	-
POLISHING	-	NEXT ASSY	USED ON
MACHINING	-	APPLICATION	
TOOLING FIXTURE #	REMOVE ALL BURRS AND SHARP EDGES		

UNITS ARE: INCHES [MM]		
TOLERANCES ARE:		
FRACTIONS	DECIMALS	ANGLES
±1/16"	.X ±.1 [2.5]	±1°
	.XX ±.06 [1.5]	
(X.XXX) DENOTES CRITICAL DIMS.		
ALL THREADS ARE CRITICAL		
DRAWN	JINSON	08/16/18
CHECKED	J.M.	08/16/18
APPROVED	J.M.	08/16/18

BRASSTECH 2001 CARNEGIE AVE.
INCORPORATED SANTA ANA, CA 92705
(949) 417-5207

**AIR ACTV ELECTRIC SWITCH,
CONTEMP**

DWG NO. **3190-5811** REV **A**

SCALE .500 REF. - SHEET 1 OF 2

COPYRIGHT 2005 BRASSTECH, INC.
THESE DRAWINGS AND THE DESIGNS
DEPICTED HEREIN ARE THE PROPRIETARY
PROPERTY OF BRASSTECH. ANY USE
OR REPRODUCTION IS SUBJECT TO
THE EXPRESS APPROVAL OF BRASSTECH.
UNAUTHORIZED USE IS STRICTLY
PROHIBITED. ALL RIGHTS RESERVED.

ZONE	REV	DESCRIPTION	DATE	APPROVED
-	A	EN-4300r	09/24/21	R.S.
-	-	EN-3549	08/16/18	J.M.

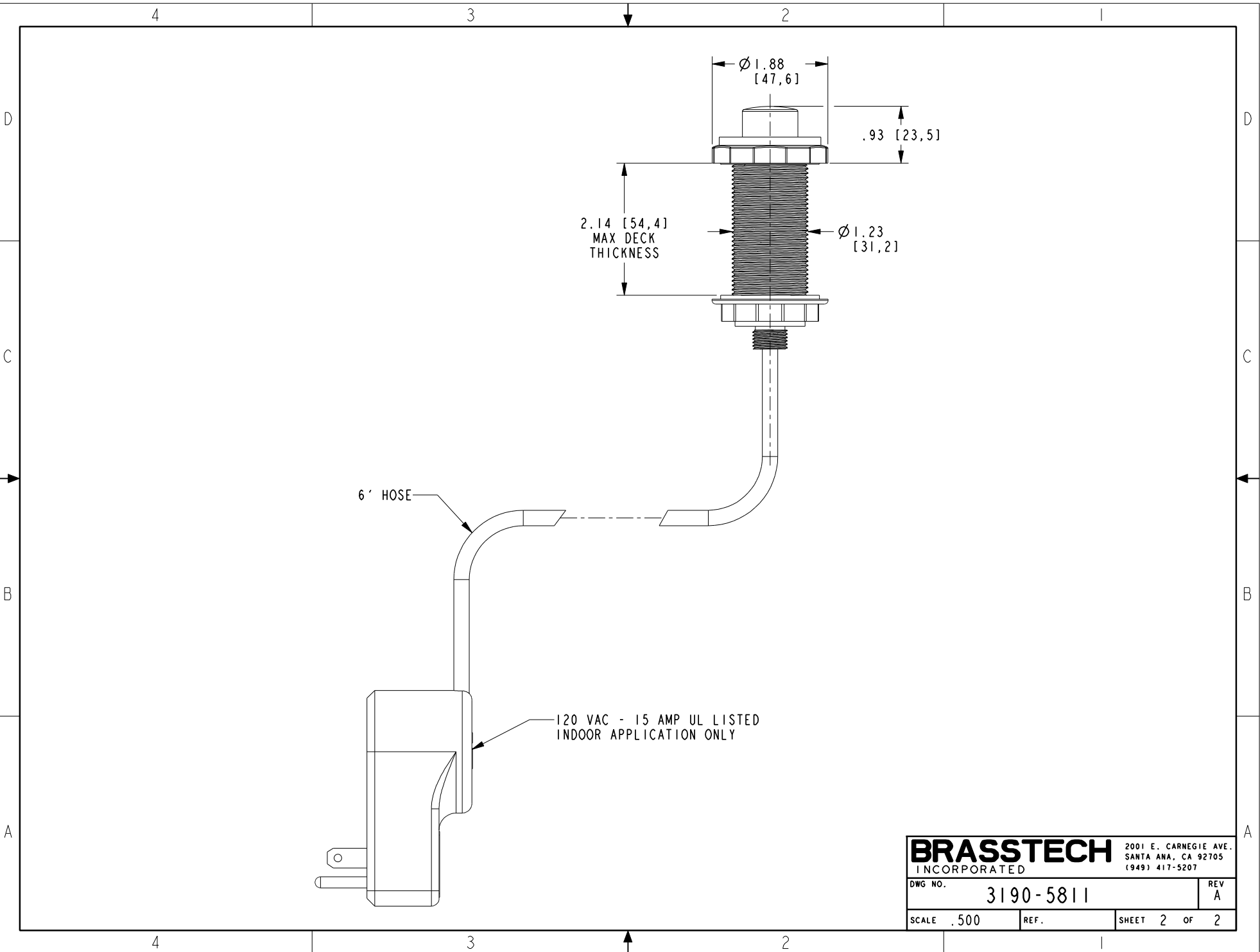

BRASSTECH		2001 E. CARNEGIE AVE. SANTA ANA, CA 92705 (949) 417-5207	
DWG NO.	3190-5811	REV	A
SCALE	.500	REF.	SHEET 2 OF 2