

NOTES:

1. TO INSPECT ASSEMBLY, FOLLOW FIRST ARTICLE AND IN PROCESS INSPECTION SHEET.
2. CUT AND SHORTEN O-RING BY .13" TO .20" IN LENGTH BEFORE INSTALLING.
3. SLIT O-RING BEFORE INSTALLING.
4. APPLY LOCTITE 242.
5. CONNECT WHITE AND RED TUBINGS TOGETHER AND WATER TEST WHOLE UNIT.
6. BAG 92194 IN A SEPARATE BAG.
7. REWORK CARTRIDGE ASSY IF THE HANDLE DOES NOT RETURN TO THE "OFF" POSITION AUTOMATICALLY AFTER WATER TESTING.
8. INSTALLATION TORQUE: 8-14 LB-FT.
9. INSTALLATION TORQUE: 78 LB-IN +/- 6 LB-IN.
10. LUBRICATE SPRING WITH DOW CORNING III.
11. APPLY THIN FILM OF DOW CORNING III.
12. APPLY LOCTITE 680.
13. INSTALLATION TORQUE: 10 -14 LB-IN.

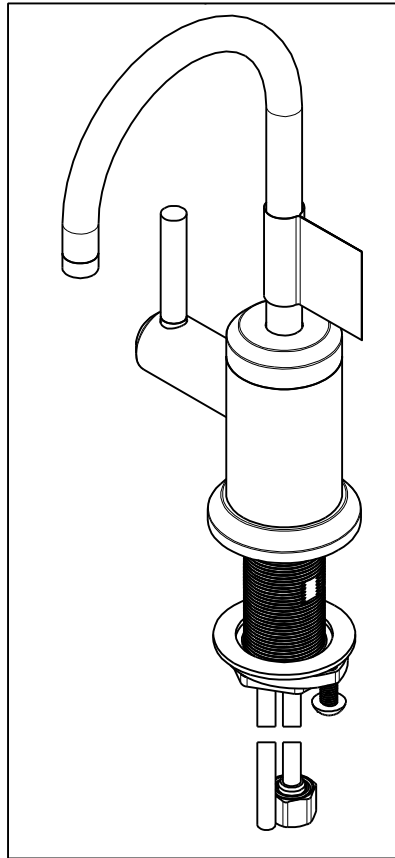

BILL OF MATERIAL (CURRENT LEVEL)

ITEM	PT/ASSY	DESCRIPTION	TYPE	QTY.
1	12649	ESCUTCHEON	PART	1
2	91772	O-RING, # 2-131, EP, 50 DURO - GREY	PART	1
3	13288	BODY	PART	1
4	50717	WATER DISP SPOUT RETAINER	PART	1
5	91023	O-RING, #2- 019, EPDM, 65-75 DURO, NSF 61	PART	1
6	5-052	SPOUT ASM	ASSEMBLY	1
7	91382	O-RING, #2- 012, TEFLON,	PART	1
8	91017	O-RING, #2- 012, EPDM, 65-75 DURO, NSF 61	PART	2
9	12650	BODY CAP	PART	1
10	91383	O-RING, #2- 014, TEFLON, NSF 61	PART	1
11	50714	WATER DISP. CAR.T HOLDER	PART	1
12	12651	WATER DISP HANDLE (CONT.)	PART	1
13	92192	SCRW, 10-32 X 5/8 SKT HD CUP PT SS	PART	1
14	91374	RED IDENTIFIER	PART	1
15	50721	WATER DISP LEVER (CONT.)	PART	1
16	5-061	ADAPTER/CARTRIDGE ASSY	ASSEMBLY	1
17	1-431	RED SUPPLY LINE	ASSEMBLY	1
18	1-433	GREY SUPPLY LINE	ASSEMBLY	1
19	1-432	BLUE SUPPLY LINE	ASSEMBLY	1
20	13070	RETAINER PLATE	PART	1
21	92016	SCRW, 10-24 X 3/4 SKT HD FLT PT SS	PART	1
22	98043	TAG LABEL, HOT WATER WARNING	PART	1
23	13289	NIPPLE	PART	1
24	1-393	1-1/8 18 UNEF MOUNTING KIT	ASSEMBLY	1
25	92194	COUPLING, 3/8" X 1/4"	PART	1
26	91424	WSHR, .81 ID X .93 OD X .045 THK, FLT, PLST	PART	1

ZONE	REV	DESCRIPTION	DATE	APPROVED
-	G	EN-4300jj	07/22/21	R.S.
-	F	EN-3634A	11/26/19	C.G.
-	E	EN-3941	08/28/19	C.G.
-	D	EN-3862	05/09/19	C.G.
-	C	EN-3722	02/08/19	C.G.
-	B	EN-3558a	01/01/19	V.V.
-	A	EN-3693	08/29/18	J.M.
-	-	EN-3076	03/14/17	J.M.

COPYRIGHT 2005 BRASSTECH, INC. THESE DRAWINGS AND THE DESIGNS DEPICTED HEREIN ARE THE PROPRIETARY PROPERTY OF BRASSTECH. ANY USE OR REPRODUCTION IS SUBJECT TO THE EXPRESS APPROVAL OF BRASSTECH. UNAUTHORIZED USE IS STRICTLY PROHIBITED. ALL RIGHTS RESERVED.

TESTING	-	-	-
ASSEMBLY	-	-	-
PLATING	-	-	-
POLISHING	-	NEXT ASSY	USED ON
MACHINING	-	APPLICATION	
TOOLING FIXTURE #	REMOVE ALL BURRS AND SHARP EDGES		

UNITS ARE: INCHES [MM]	
TOLERANCES ARE:	
FRACTIONS DECIMALS	ANGLES
±1/16"	.X ±.1 [2.5]
	.XX ±.06 [1.5]
(X.XXX) DENOTES CRITICAL DIMS.	
ALL THREADS ARE CRITICAL	
DRAWN	JINSON 07/22/21
CHECKED	R.S. 07/22/21
APPROVED	R.S. 07/22/21

**BRASSTECH** 2001 CARNEGIE AVE. SANTA ANA, CA 92705 (949) 417-5207  
INCORPORATED

WATER DISPENSER - HOT

DWG NO.	3200-5613	REV	G
SCALE	.375	REF.	-
SHEET	1	OF	3

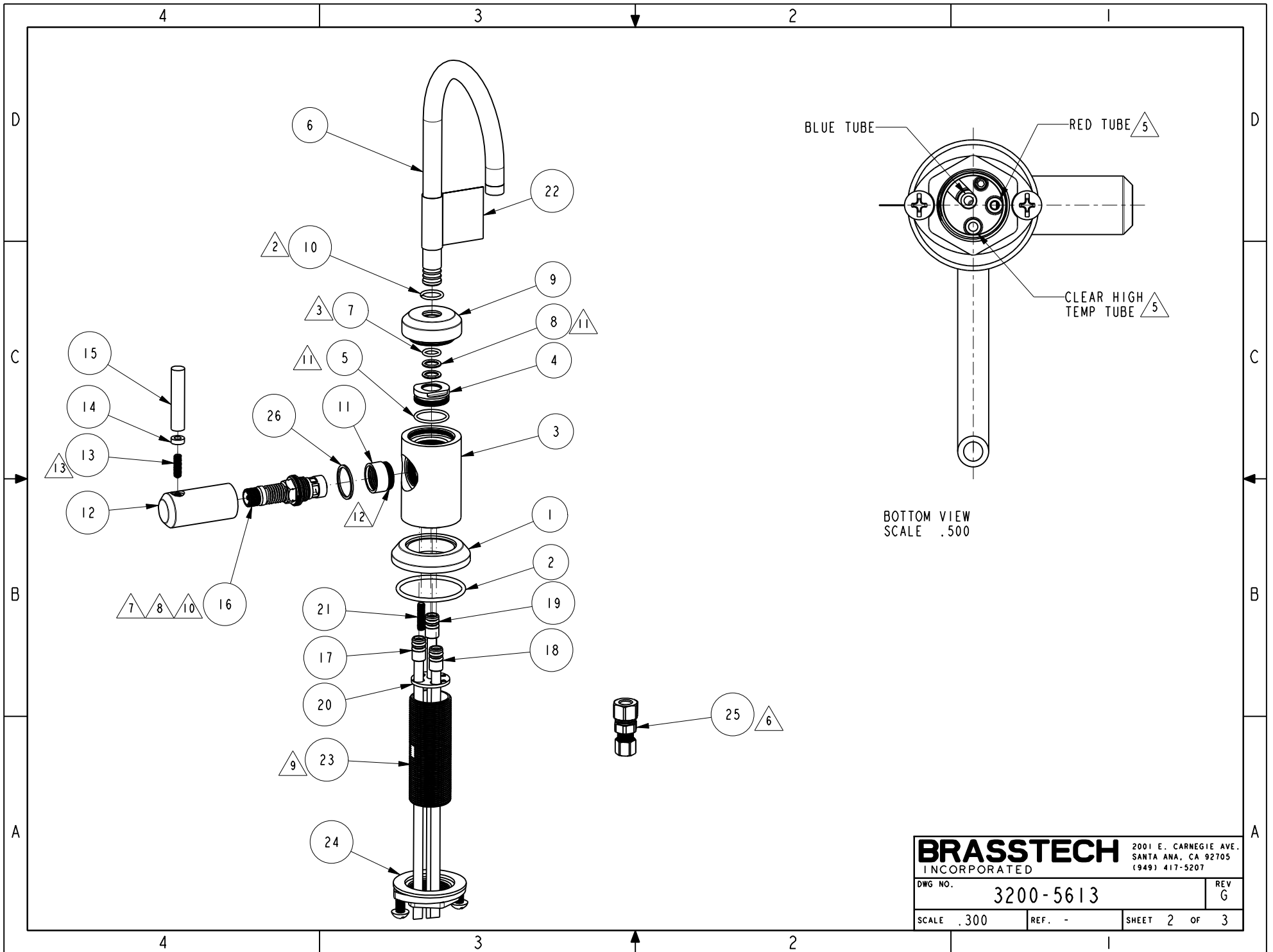

<b>BRASSTECH</b>		2001 E. CARNEGIE AVE. SANTA ANA, CA 92705 (949) 417-5207	
DWG NO.	3200-5613	REV	G
SCALE	.300	REF.	-
SHEET 2		OF 3	

