

NOTES:

1. TO INSPECT ASSEMBLY, FOLLOW FIRST ARTICLE AND IN PROCESS INSPECTION SHEET.
2. APPLY LOCTITE 680.
3. CUT AND SHORTEN O-RING BY .13" TO .20" IN LENGTH BEFORE INSTALLING.
4. SLIT O-RING BEFORE INSTALLING.
5. APPLY LOCTITE 242.
6. CONNECT WHITE AND RED TUBINGS TOGETHER AND WATER TEST WHOLE UNIT.
7. BAG 92194 IN A SEPARATE BAG.
8. REWORK CARTRIDGE ASSY IF THE HANDLE DOES NOT RETURN TO THE 'OFF' POSITION AUTOMATICALLY AFTER WATER TESTING.
9. INSTALLATION TORQUE: 8-14 LB-FT.
10. INSTALLATION TORQUE: 78 LB-IN +/- 6 LB-IN.
11. LUBRICATE SPRING WITH DOW CORNING III.
12. APPLY THIN FILM OF DOW CORNING III.

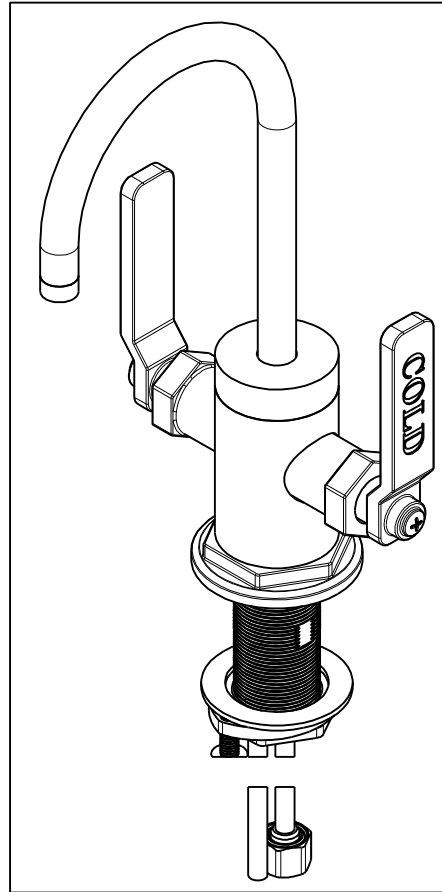

BILL OF MATERIAL (CURRENT LEVEL)

ITEM	PT/ASSY	DESCRIPTION	TYPE	QTY.
1	1-134	CARTR 3/8 HOT 1/4 TR	PART	1
2	1-393	1-1/8 18 UNEF MOUNTING KIT	ASSEMBLY	1
3	1-431	RED SUPPLY LINE	ASSEMBLY	1
4	1-432	BLUE SUPPLY LINE	ASSEMBLY	1
5	1-433	GREY SUPPLY LINE	ASSEMBLY	1
6	5-052	SPOUT ASM	ASSEMBLY	1
7	5-061	ADAPTER/CARTRIDGE ASSY	ASSEMBLY	1
8	20-338	ESCUTCHEON ASM	ASSEMBLY	1
9	20-339	HANDLE ASM, COLD	ASSEMBLY	1
10	20-340	HANDLE ASM, HOT	ASSEMBLY	1
11	12750	ADAPTER	PART	1
12	12926	BONNET DECO	PART	2
13	13070	RETAINER PLATE	PART	1
14	13287	WATER DISP. BODY H/C (CONT)	PART	1
15	13289	NIPPLE	PART	1
16	50714	WATER DISP. CAR.T HOLDER	PART	2
17	50716	WATER DISP BODY CAP (CONT.)	PART	1
18	50717	WATER DISP SPOUT RETAINER	PART	1
19	91017	O-RING, #2- 012, EPDM, 65-75 DURO, NSF 61	PART	2
20	91023	O-RING, #2- 019, EPDM, 65-75 DURO, NSF 61	PART	1
21	91382	O-RING, #2- 012, TEFLON,	PART	1
22	91383	O-RING, #2- 014, TEFLON, NSF 61	PART	1
23	92016	SCRW, 10-24 X 3/4 SKT HD FLT PT SS	PART	1
24	92194	COUPLING, 3/8" X 1/4"	PART	1
25	92862	SCRW, M4 X 18 SKT FLT HD SS	PART	1
26	98043	TAG LABEL, HOT WATER WARNING	PART	1

ZONE	REV	DESCRIPTION	DATE	APPROVED
-	C	EN-4300jj	07/22/21	R.S.
-	B	EN-3634A	11/21/19	C.G.
-	A	EN-3857	04/25/19	J.M.
-	-	EN-3443	09/17/18	J.M.

COPYRIGHT 2005 BRASSTECH, INC. THESE DRAWINGS AND THE DESIGNS DEPICTED HEREIN ARE THE PROPRIETARY PROPERTY OF BRASSTECH. ANY USE OR REPRODUCTION IS SUBJECT TO THE EXPRESS APPROVAL OF BRASSTECH. UNAUTHORIZED USE IS STRICTLY PROHIBITED. ALL RIGHTS RESERVED.

TESTING	-	-	-
ASSEMBLY	-	-	-
PLATING	-	-	-
POLISHING	-	NEXT ASSY	USED ON
MACHINING	-	APPLICATION	
TOOLING FIXTURE #	REMOVE ALL BURRS AND SHARP EDGES		

UNITS ARE: INCHES [MM]		
TOLERANCES ARE:		
FRACTIONS DECIMALS	ANGLES	
±1/16"	±1°	
.X ±.1	[2.5]	
.XX ±.06	[1.5]	
(X.XXX) DENOTES CRITICAL DIMS.		
ALL THREADS ARE CRITICAL		
DRAWN	JINSON	07/22/21
CHECKED	R.S.	07/22/21
APPROVED	R.S.	07/22/21

BRASSTECH 2001 CARNEGIE AVE.
SANTA ANA, CA 92705
(949) 417-5207

INCORPORATED

WATER DISPENSER - HOT & COLD

DWG NO. 3220-5603

REV C

SCALE .400 REF. - SHEET 1 OF 3

