

NOTES:

1. TO INSPECT ASSEMBLY, FOLLOW FIRST ARTICLE AND IN PROCESS INSPECTION SHEET.
2. PUT THESE ITEMS IN SEPARATE PLASTIC BAGS.
3. TORQUE 135 +/-5 LB-IN.
4. APPLY THIN COAT OF SILICON GREASE FOR ALL O-RINGS BEFORE INSTALLATION.
5. APPLY LOCTITE 242, IF SCREW DOES NOT HAVE NYLON PATCH.
6. APPLY LOCTITE 680.
7. PULL OUT HOSE AND APPLY SILICON GREASE, BETWEEN HOUSE AND SPOUT, 10" FROM OUTLET TO HOSE.
8. TORQUE SWIVEL NUT TO 10 +/-2 LB-IN.
9. TORQUE TO 10 +/-2 LB-FT.
10. TORQUE TO 7 +/-2 LB-IN.
11. PARTIALLY THREAD MOUNTING KIT ONTO SHANK.
12. DO NOT DOCK SPRAY HEAD TO SPOUT WHEN PACKAGING.

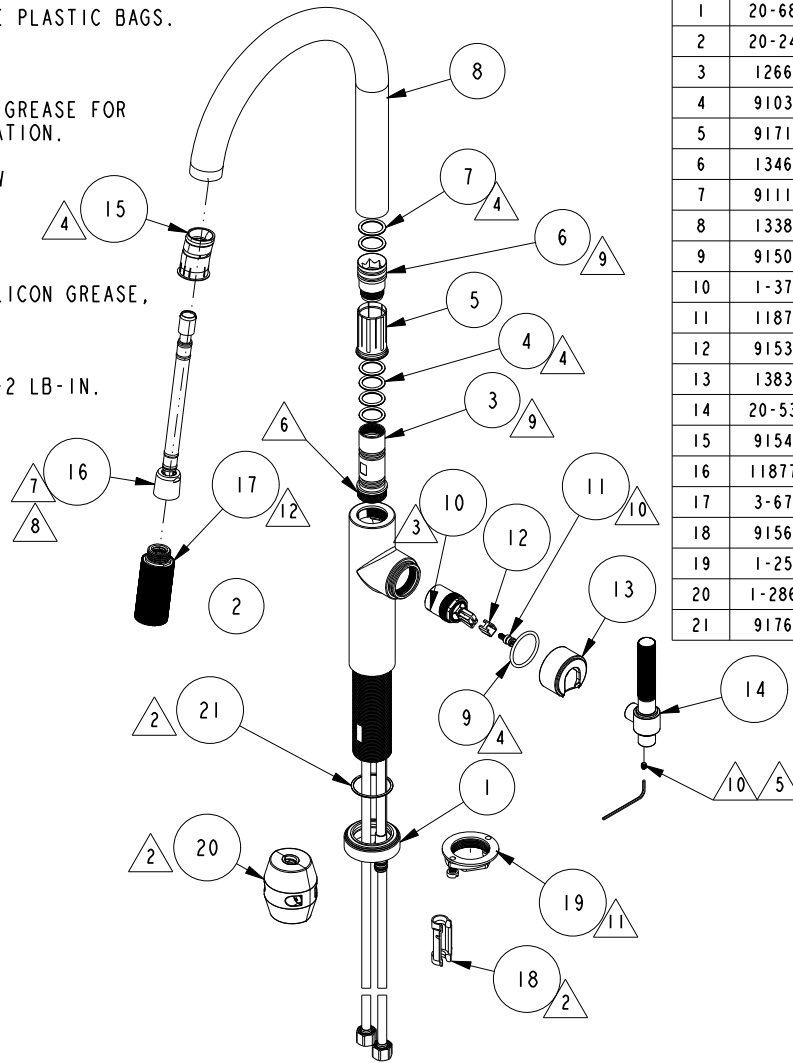

**BILL OF MATERIAL (CURRENT LEVEL)**

ITEM	PT/ASSY	DESCRIPTION	TYPE	QTY.
1	20-683	ESCUTCHEON ASM	ASSEMBLY	1
2	20-245	MAIN BODY ASM	ASSEMBLY	1
3	12667	SPOUT ADAPTER	PART	1
4	91030	O-RING, #2- 115, EPDM, 65-75 DURO, NSF 61	PART	4
5	91712	SLEEVE	PART	1
6	13464	ADAPTER EXTENSION	PART	1
7	91114	O-RING, #2- 116, EPDM, 65-75 DURO, NSF 61	PART	2
8	13385	PULLDOWN SPOUT - LONG	PART	1
9	91505	O-RING, #2-123, EPDM, 65-75 DURO	PART	1
10	1-371	CARTRIDGE	PART	1
11	11874	HANDLE ADAPTER SCREW	PART	1
12	91534	CARTRIDGE STEM INSERT	PART	1
13	13838	25MM PULLDOWN HUB	PART	1
14	20-532	KNURLED HANDLE ASM	ASSEMBLY	1
15	91544	MAGNET DOCKING	ASSEMBLY	1
16	11877A	HOSE, PULLDOWN, GREY	ASSEMBLY	1
17	3-673	SPRAY HEAD	ASSEMBLY	1
18	91568	RETAINER CLIP	PART	1
19	1-256	MOUNTING KIT	ASSEMBLY	1
20	1-286A	WEIGHT	ASSEMBLY	1
21	91764	O-RING, #2-027, EP, 50 DURO - GREY	PART	1

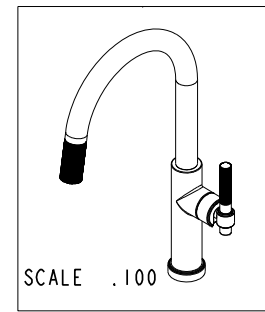

COPYRIGHT 2005 BRASSTECH, INC. THESE DRAWINGS AND THE DESIGNS DEPICTED HEREIN ARE THE PROPRIETARY PROPERTY OF BRASSTECH. ANY USE OR REPRODUCTION IS SUBJECT TO THE EXPRESS APPROVAL OF BRASSTECH. UNAUTHORIZED USE IS STRICTLY PROHIBITED. ALL RIGHTS RESERVED.

TESTING	-	-	-
ASSEMBLY	-	-	-
PLATING	-	-	-
POLISHING	-	NEXT ASSY	USED ON
MACHINING	-	APPLICATION	
TOOLING FIXTURE #	REMOVE ALL BURRS AND SHARP EDGES		

**BRASSTECH** 2001 CARNEGIE AVE. SANTA ANA, CA 92705 (949) 417-5207  
INCORPORATED

**SGL HL 25MM PULL DOWN**

DWG NO. **3290-5143** REV -

SCALE .150 REF. - SHEET 1 OF 2

ZONE	REV	DESCRIPTION	DATE	APPROVED
-	-	EN-4550	08/30/22	J.M.

