

NOTES:

(NI) 1. FIT / FORM / FUNCTION SHALL FOLLOW PS-E.008.

2. APPLY LOCTITE 680.

BILL OF MATERIAL (CURRENT LEVEL)

ITEM	PT/ASSY	DESCRIPTION	TYPE	QTY.
1	6XXB	MOUNTING BRACKET	PART	1
2	1-206	HARDWARE PACK	ASSEMBLY	1
3	2-656	HANDLE ESCUTCHEON ASM	ASSEMBLY	1
4	40725	SINGLE ROBE HOOK POST	PART	1
5	40737	FINIAL, ROBE HOOK	PART	1
6	92031	SCRW, M6 X 1 X 6 SKT HD CUP PT W/ SELF LOC SS	PART	1
7	10615	HEX KEY, 3MM ALLOY STEEL	PART	1

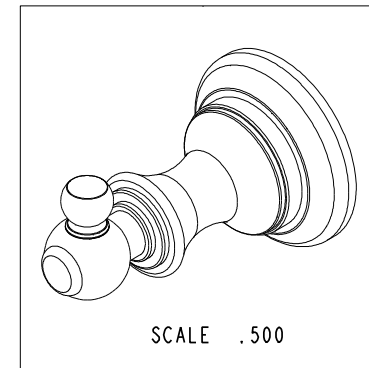
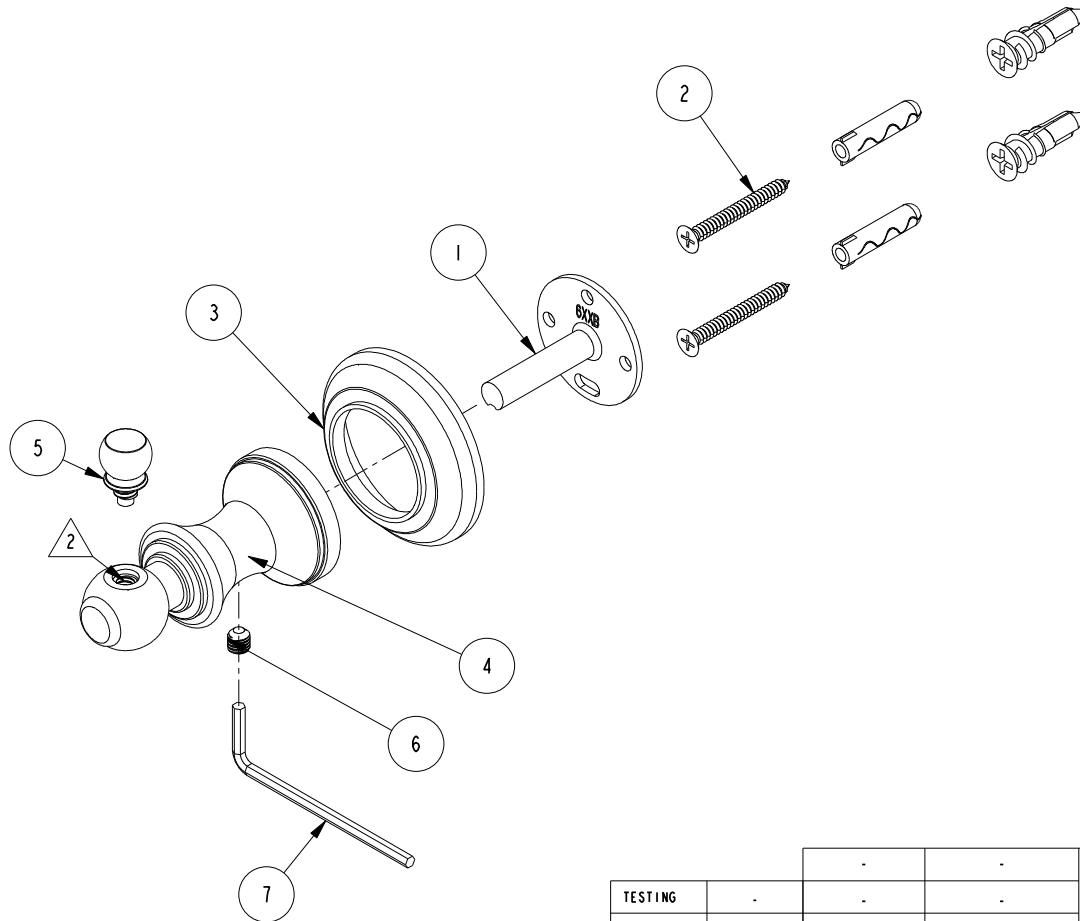

TESTING	-	-	-
ASSEMBLY	-	-	-
PLATING	-	-	-
POLISHING	-	NEXT ASSY	USED ON
MACHINING	-	APPLICATION	
TOOLING FIXTURE #	REMOVE ALL BURRS AND SHARP EDGES		

UNITS ARE: INCHES [MM]		
TOLERANCES ARE:		
FRACTIONS	DECIMALS	ANGLES
±1/16"	.X ±.1 [2.5]	±1°
	.XX ±.06 [1.5]	
(X.XXX) DENOTES CRITICAL DIMS.		
ALL THREADS ARE CRITICAL		
DRAWN	R.S.	09/03/19
CHECKED	J.M.	09/03/19
APPROVED	J.M.	09/03/19

BRASSTECH 2001 CARNEGIE AVE.
INCORPORATED SANTA ANA, CA 92705
(949) 417-5207

ROBE HOOK

-	A	EN-3950	09/03/19	J.M.
-	-	EN-1266	06/10/10	J.M.
ZONE	REV	DESCRIPTION	DATE	APPROVED

COPYRIGHT 2005 BRASSTECH, INC. THESE DRAWINGS AND THE DESIGNS DEPICTED HEREIN ARE THE PROPRIETARY PROPERTY OF BRASSTECH. ANY USE OR REPRODUCTION IS SUBJECT TO THE EXPRESS APPROVAL OF BRASSTECH. UNAUTHORIZED USE IS STRICTLY PROHIBITED. ALL RIGHTS RESERVED.

DWG NO.	35-12	REV	A
SCALE	.500	REF.	-
SHEET	1	OF	2

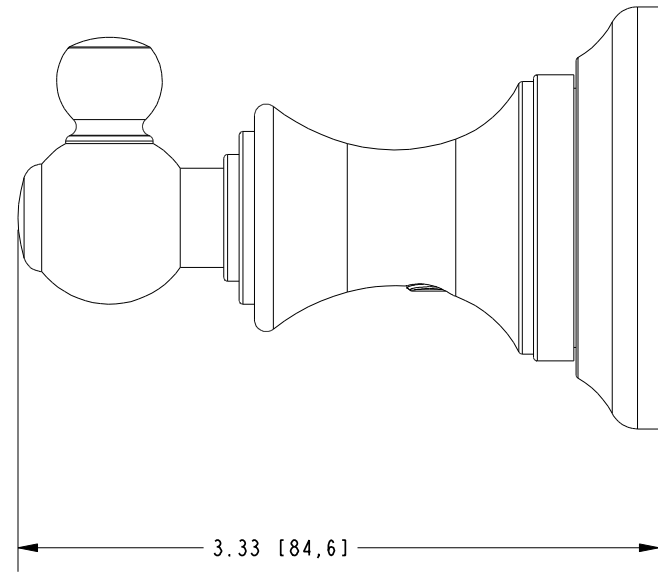
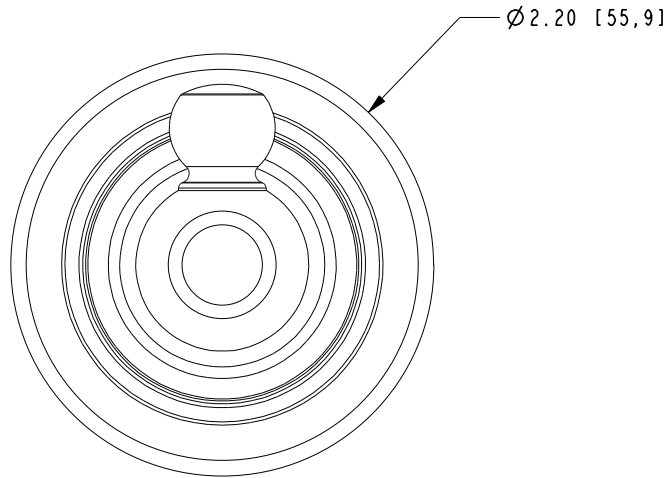

BRASSTECH		2001 E. CARNEGIE AVE. SANTA ANA, CA 92705 (949) 417-5207	
DWG NO.	35-12	REV	A
SCALE	1.00	REF.	-
SHEET 2		OF 2	