

NOTES:

(N1) 1. FIT / FORM / FUNCTION SHALL FOLLOW PS-E.008.

(N2) 2. APPLY LOCTITE 680 AT 18 IN-LB TORQUE.

BILL OF MATERIAL (CURRENT LEVEL)

ITEM	PT/ASSY	DESCRIPTION	TYPE	QTY.
1	1-206	HARDWARE PACK	ASSEMBLY	1
2	10615	HEX KEY, 3MM ALLOY STEEL	PART	1
3	40506	POST, TOWEL BAR	PART	1
4	40510	A SHAPED RING - TOWEL RING	PART	1
5	40525	END POST, TOWEL RING	PART	1
6	92001	SCRW, 8-32 X 3/16 SKT HD FLT PT SS	PART	1
7	92031	SCRW, M6 X 1 X 6 SKT HD CUP PT W/ SELF LOC SS	PART	1
8	92527	SCRW, 8-32 X 3/8 SKT CAP HD SS	PART	1
9	6XXB	MOUNTING BRACKET	PART	1
10	XX05C	TOWEL RING COUPLER	PART	1

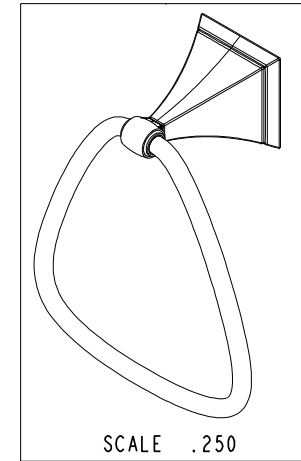
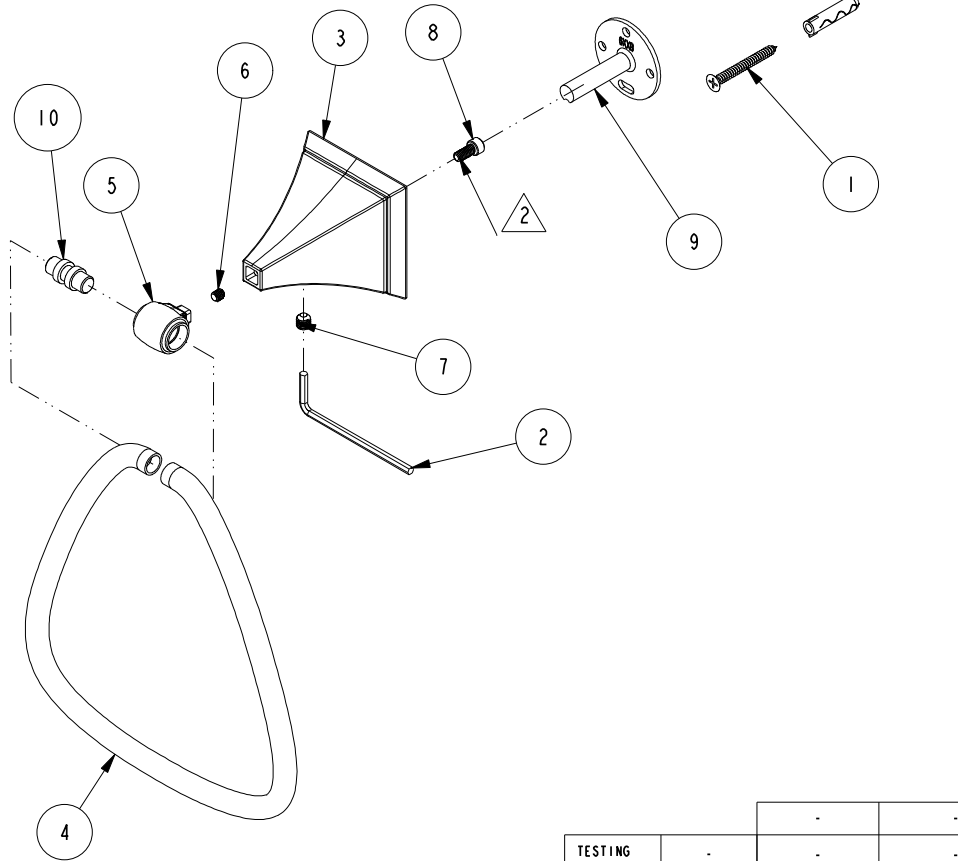

TESTING	-	-	-
ASSEMBLY	-	-	-
PLATING	-	-	-
POLISHING	-	NEXT ASSY	USED ON
MACHINING	-	APPLICATION	
TOOLING FIXTURE #	REMOVE ALL BURRS AND SHARP EDGES		

UNITS ARE: INCHES [MM]
 TOLERANCES ARE:
 FRACTIONS DECIMALS ANGLES
 $\pm 1/16"$.X $\pm .1$ [2.5] $\pm 1^\circ$
 .XX $\pm .06$ [1.5]

(X.XXX) DENOTES CRITICAL DIMS.
 ALL THREADS ARE CRITICAL

DRAWN	-	-
CHECKED	-	-
APPROVED	-	-

BRASSTECH 2001 CARNEGIE AVE.
 INCORPORATED SANTA ANA, CA 92705
 (949) 417-5207

'A' - SHAPE TOWEL RING

DWG NO.	41-09	REV	B
SCALE	.313	REF.	-
SHEET	1	OF	2

-	B	EN-4032	12/04/19	R. S.	COPYRIGHT 2005 BRASSTECH, INC. THESE DRAWINGS AND THE DESIGNS DEPICTED HEREIN ARE THE PROPRIETARY PROPERTY OF BRASSTECH. ANY USE OR REPRODUCTION IS SUBJECT TO THE EXPRESS APPROVAL OF BRASSTECH. UNAUTHORIZED USE IS STRICTLY PROHIBITED. ALL RIGHTS RESERVED.
-	A	EN-3162	10/11/16	J. M.	
-	-	EN-2087	09/20/13	J. M.	
ZONE	REV	DESCRIPTION	DATE	APPROVED	

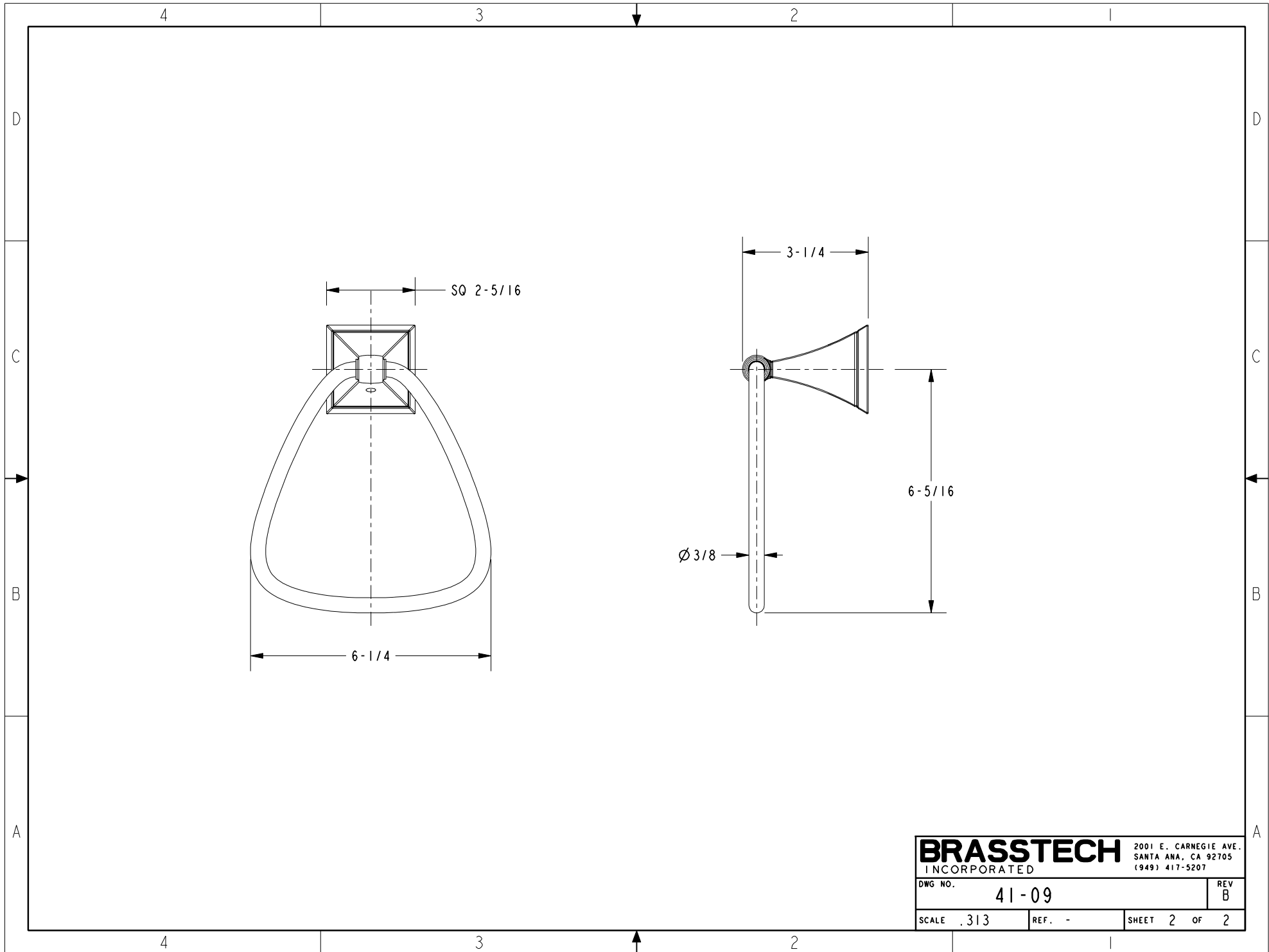

BRASSTECH		2001 E. CARNEGIE AVE. SANTA ANA, CA 92705 (949) 417-5207	
DWG NO.	41-09	REV	B
SCALE	.313	REF.	-
		SHEET	2 OF 2