

NOTES:

1. TO INSPECT ASSEMBLY, FOLLOW FIRST ARTICLE AND IN PROCESS INSPECTION SHEET.

**BILL OF MATERIAL (CURRENT LEVEL)**

ITEM	PT/ASSY	DESCRIPTION	TYPE	QTY.
1	3014	P-TRAP ASM 1-1/4" W/ BOX FLANGE	ASSEMBLY	1
2	416X	ANGLE VALVE XHDL 1/2SWTX3/8CMP	ASSEMBLY	2
3	432	SUPPLY TUBE 3/8	ASSEMBLY	2

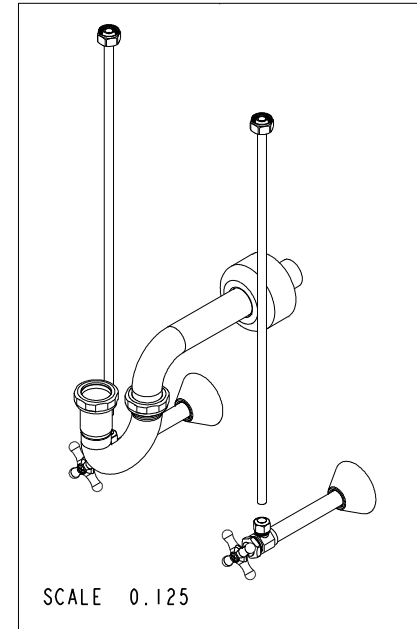
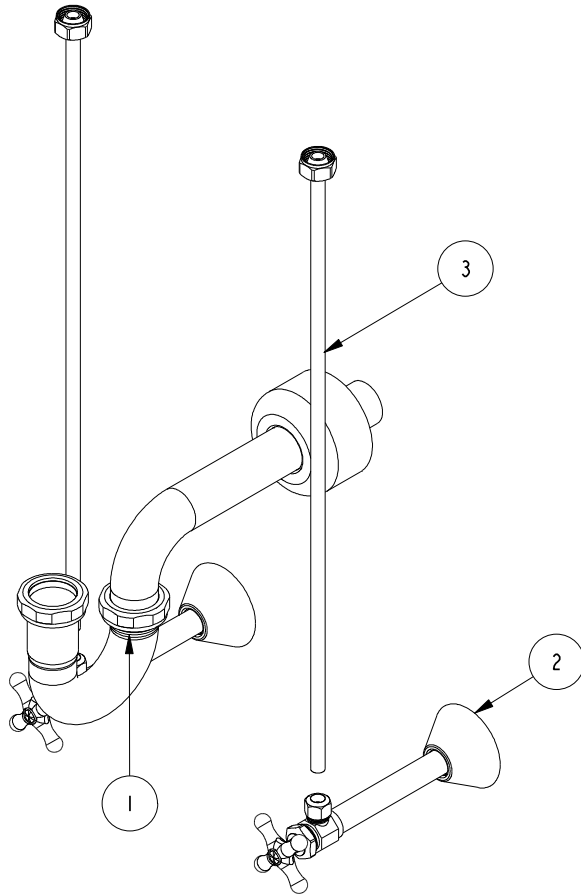

ZONE	REV	DESCRIPTION	DATE	APPROVED
-	B	EN-430011	10/20/21	R.S.
-	A	EN-3464	11/13/17	V.V.
-	-	RELEASED	07/20/15	H.LE

COPYRIGHT 2005 BRASSTECH, INC. THESE DRAWINGS AND THE DESIGNS DEPICTED HEREIN ARE THE PROPRIETARY PROPERTY OF BRASSTECH. ANY USE OR REPRODUCTION IS SUBJECT TO THE EXPRESS APPROVAL OF BRASSTECH. UNAUTHORIZED USE IS STRICTLY PROHIBITED. ALL RIGHTS RESERVED.

TESTING	-	-	-
ASSEMBLY	-	-	-
PLATING	-	-	-
POLISHING	-	NEXT ASSY	USED ON
MACHINING	-	APPLICATION	
TOOLING FIXTURE #	REMOVE ALL BURRS AND SHARP EDGES		

UNITS ARE: INCHES [MM]	
TOLERANCES ARE:	
FRACTIONS	DECIMALS ANGLES
±1/16"	±.1 [2.5] ±1°
.X	±.1 [2.5]
.XX	±.06 [1.5]
(X.XXX) DENOTES CRITICAL DIMS. ALL THREADS ARE CRITICAL	
DRAWN	RAVINDRA 07/20/15
CHECKED	JINSON 07/20/15
APPROVED	H. LE 07/20/15

**BRASSTECH** 2001 CARNEGIE AVE. SANTA ANA, CA 92705 (949) 417-5207  
INCORPORATED

**FCT CONNECTION KIT**

DWG NO.	4772	REV	B
SCALE	.200	REF.	-
SHEET	1	OF	2

19.56  
[496,81]

6.46  
[164,1]

2.33  
[59,2]

Ø 2.40  
[61]

ACCEPTS  
Ø 1.25 [31,8]  
TAILPIECE

Ø 3.00  
[76,2]

1/2-14 NPSM  
FITTINGS

Ø .38  
[9,5]

3/8" COMPRESSION  
FITTINGS

Ø 1.25  
[31,8]

1.75  
[44,5]

1.13  
[28,7]

Ø .68  
[17,3]

1/2" SOLDER

7.14 [181,4]

12.38 [314,5]

**BRASSTECH**  
INCORPORATED

2001 E. CARNEGIE AVE.  
SANTA ANA, CA 92705  
(949) 417-5207

DWG NO.

4772

REV  
B

SCALE .250

REF. -

SHEET 2 OF 2