

NOTES:

1. TO INSPECT ASSEMBLY, FOLLOW FIRST ARTICLE AND IN PROCESS INSPECTION SHEET.

BILL OF MATERIAL (CURRENT LEVEL)				
ITEM	PT/ASSY	DESCRIPTION	TYPE	QTY.
1	2-224	COVERPLATE BP W/DIVERTER	ASSEMBLY	1
2	2-217	DIVERTER TRIM KIT	ASSEMBLY	1
3	3-280	HANDLE/ESCUTCHEON ASM	ASSEMBLY	1
4	1-110	BUTTON W/ADHESIVE	ASSEMBLY	1

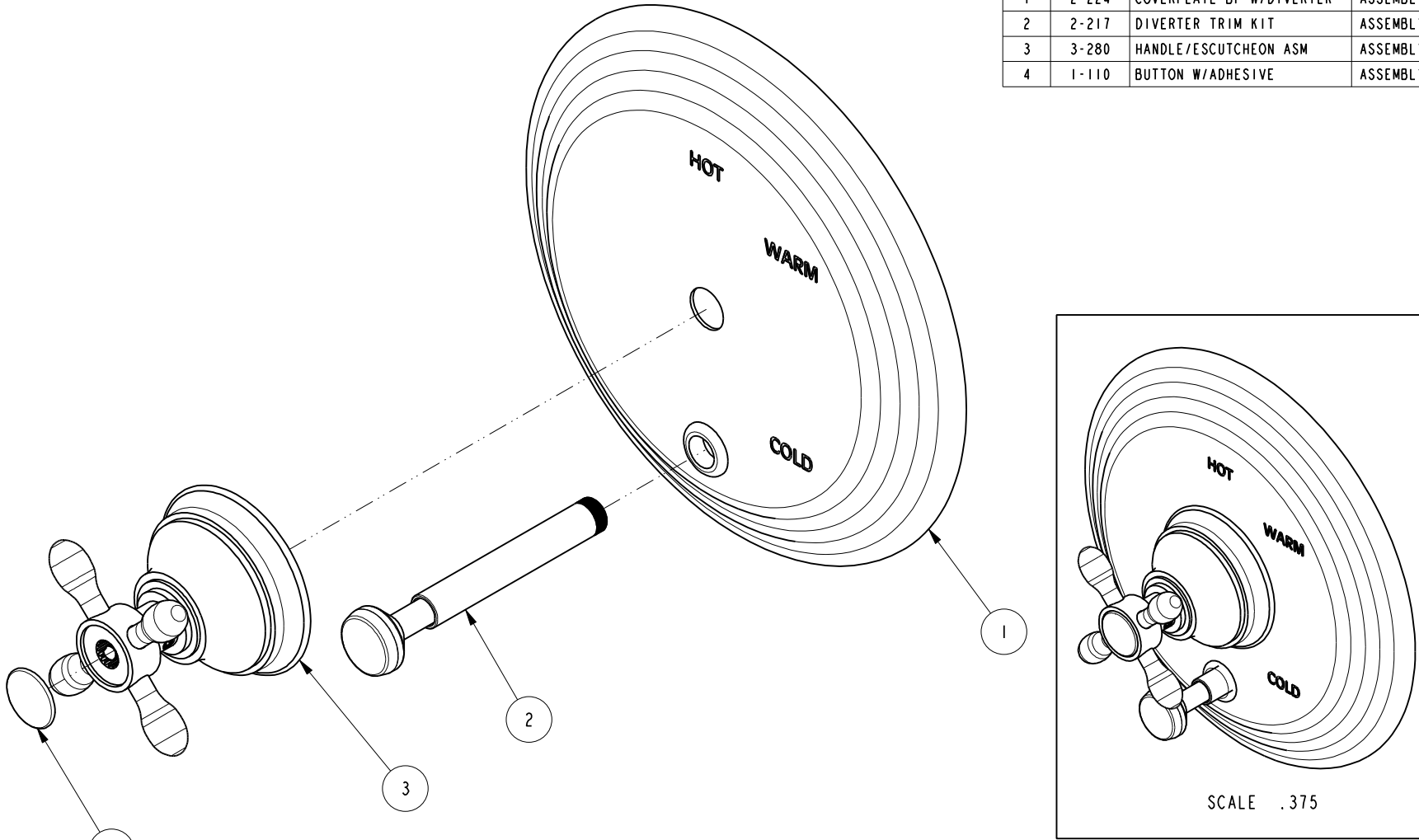

ZONE	REV	DESCRIPTION	DATE	APPROVED
-	B	EN-4300e	04/28/21	R.S.
-	A	EN-2997	09/01/16	J.A.
-	-	EN-2735	04/30/14	-

COPYRIGHT 2005 BRASSTECH, INC. THESE DRAWINGS AND THE DESIGNS DEPICTED HEREIN ARE THE PROPRIETARY PROPERTY OF BRASSTECH. ANY USE OR REPRODUCTION IS SUBJECT TO THE EXPRESS APPROVAL OF BRASSTECH. UNAUTHORIZED USE IS STRICTLY PROHIBITED. ALL RIGHTS RESERVED.

TESTING	ASSEMBLY	PLATING	POLISHING	MACHINING	TOOLING FIXTURE #	APPLICATION
-	-	-	-	-	-	REMOVE ALL BURRS AND SHARP EDGES

UNITS ARE: INCHES [MM]	
TOLERANCES ARE:	
FRACTIONS DECIMALS	ANGLES
±1/16"	±1°
.X ±.1 [2,5]	
.XX ±.06 [1,5]	
(X.XXX) DENOTES CRITICAL DIMS.	
ALL THREADS ARE CRITICAL	
DRAWN	JINSON
04/28/21	
CHECKED	R.S.
04/28/21	
APPROVED	R.S.
04/28/21	

BRASSTECH 2001 CARNEGIE AVE. SANTA ANA, CA 92705 (949) 417-5207
INCORPORATED

BP TRIM PLATE WITH DIVERTER

DWG NO. **5-1642BP** REV **B**

SCALE .500 REF. - SHEET 1 OF 2

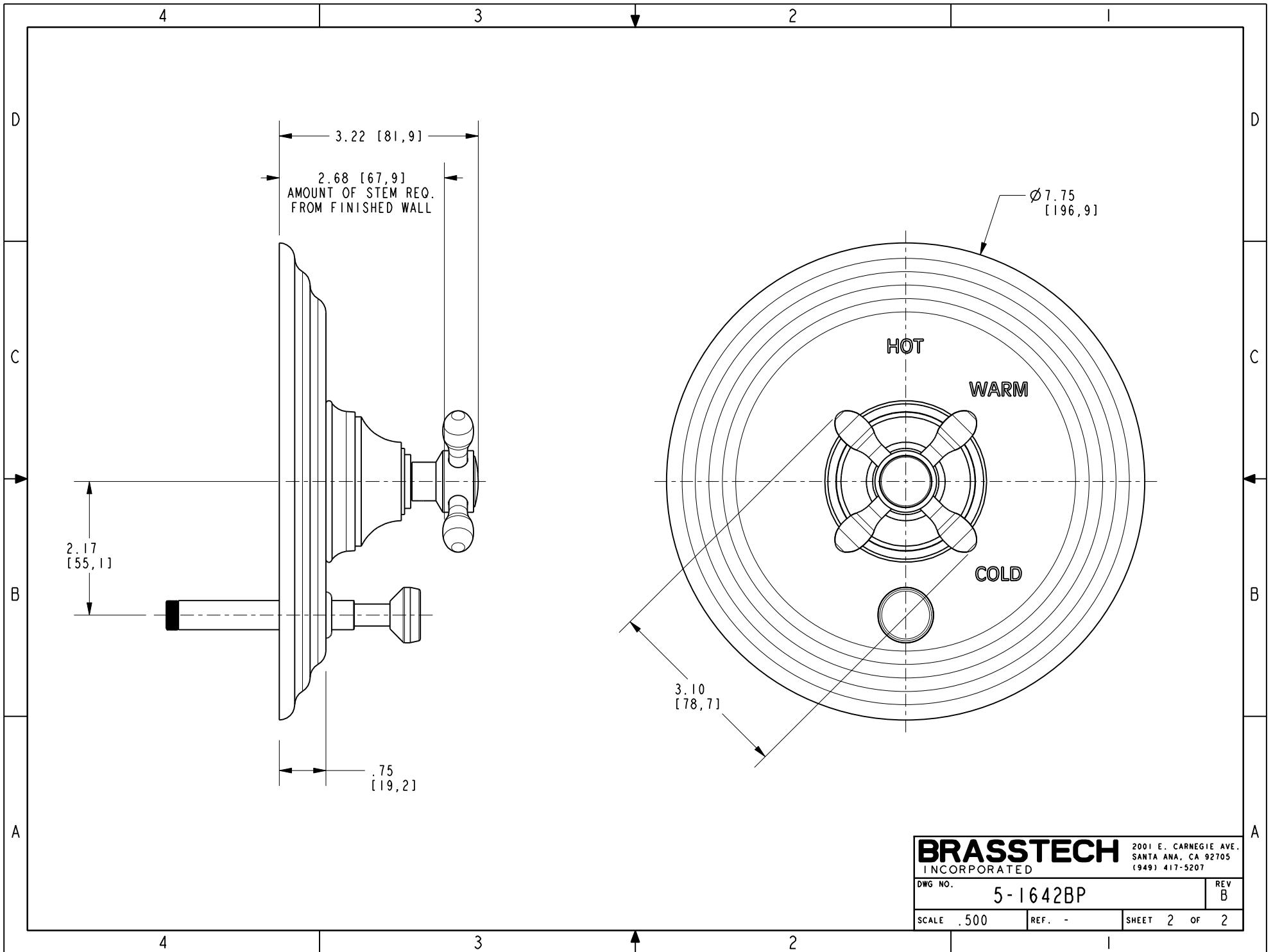

BRASSTECH		2001 E. CARNEGIE AVE. SANTA ANA, CA 92705 (949) 417-5207	
INCORPORATED			
DWG NO.	5-1642BP		REV B
SCALE	.500	REF.	-
		SHEET	2 OF 2