

REPLACEMENT PARTS

ITEM	PT/ASSY	SPECIFY FINISH	DESCRIPTION
1	2-659	YES	TUB/SOWER PLATE
2	91019		O-RING, #2- 014, EPDM, 65-75 DURO, NSF 61
3	H-78		TAPE NEO
4	2-217	YES	DIVERTER TRIM KIT
5	91065		UPPER LINK PLASTIC DIVERTER
6	2-656	YES	HANDLE ESCUTCHEON ASM
7	91757		O-RING, #2-033, EPDM, 50 DURO
8	11610	YES	HANDLE BONNET
9	2-636	YES	LEVER HANDLE ASSEMBLY
10	92141		SCREW, CAP HD 1/4-20 X 1/2
11	20-682	YES	HANDLE CAP ASM
12	91158		O-RING, 2 X 7MM ID, EPDM, 65-75 DURO
13	92846		HEX KEY, 3/16" ALLOY STEEL
14	10259		HEX NUT 9/16 X 20 MADE

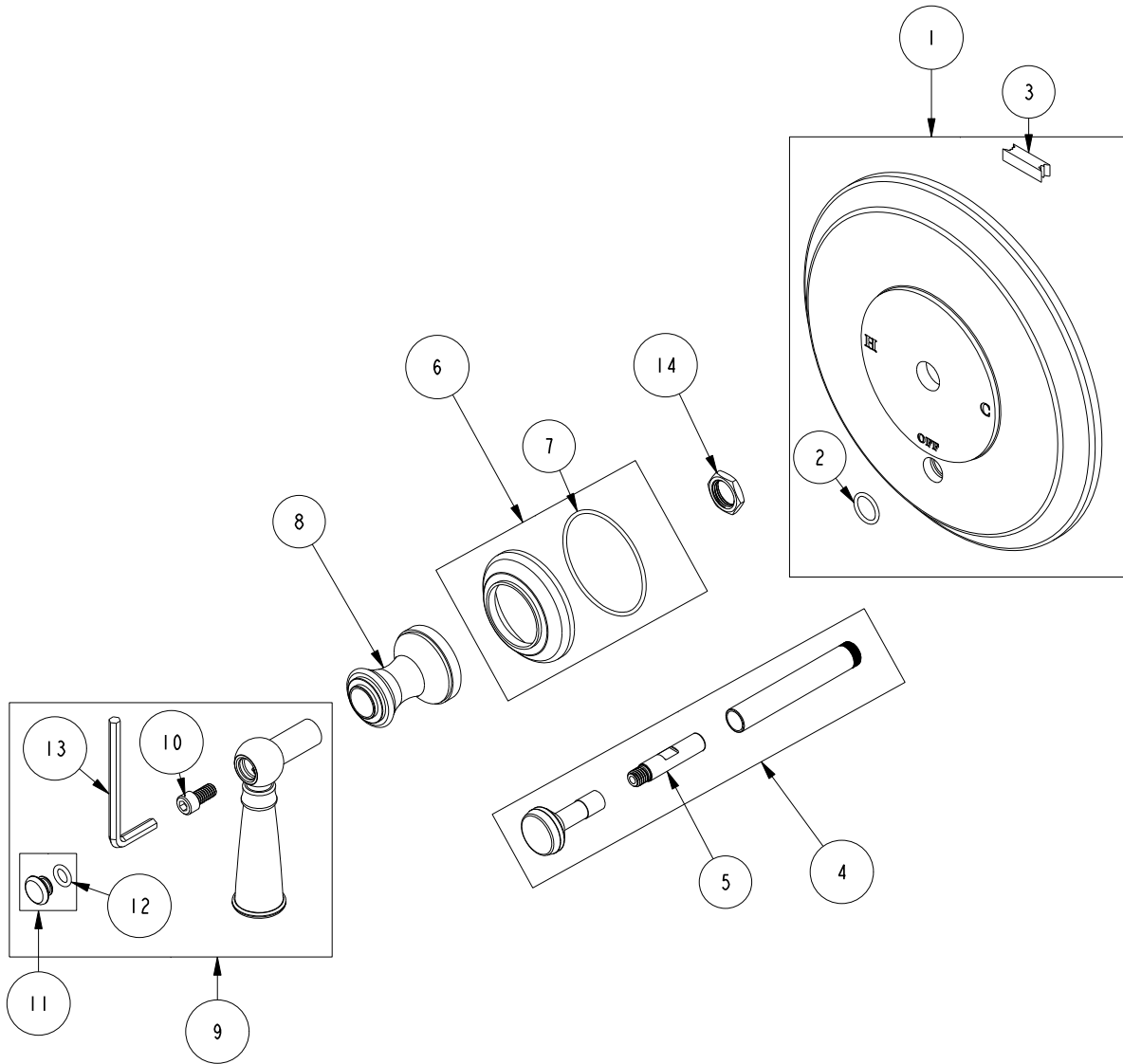

BP TRIM PLATE WITH DIVERTER
5-2452BP

REV D EN-4847 07/24/24

NEWPORT BRASS.

t: 949.417.5207 | www.newportbrass.com