

REPLACEMENT PARTS

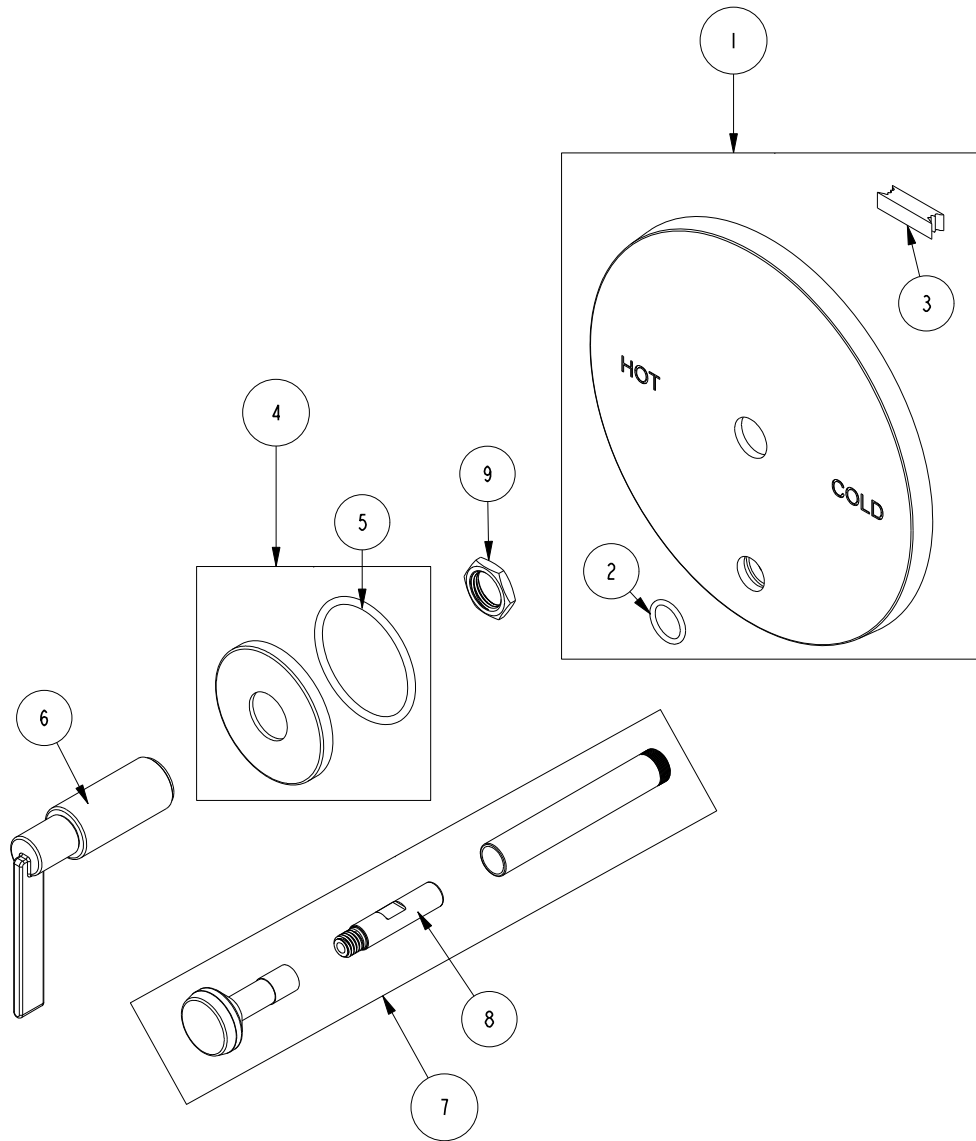

ITEM	PT/ASSY	SPECIFY FINISH	DESCRIPTION
1	20-501	YES	TUB AND SHOWER PLATE ASM
2	91019		O-RING, #2- 014, EPDM, 65-75 DURO, NSF 61
3	H-78		TAPE NEO
4	20-565	YES	ESCUTCHEON ASM
5	91768		O-RING, #2-130, EP, 50 DURO - GREY
6	20-566	YES	LEVER HANDLE ASM
7	2-217	YES	DIVERTER TRIM KIT
8	91065		UPPER LINK PLASTIC DIVERTER
9	10259		HEX NUT 9/16 X 20 MADE

BP TUB & SHOWER TRIM
5-3322BP

REV C EN-4847 07/23/24

NEWPORT BRASS.

t: 949.417.5207 | www.newportbrass.com