

NOTES:

1. TO INSPECT ASSEMBLY, FOLLOW FIRST ARTICLE AND IN PROCESS INSPECTION SHEET.

**BILL OF MATERIAL (CURRENT LEVEL)**

ITEM	PT/ASSY	DESCRIPTION	TYPE	QTY.
1	2-224	COVERPLATE BP W/DIVERTER	ASSEMBLY	1
2	2-217	DIVERTER TRIM KIT	ASSEMBLY	1
3	3-202	TRIM KIT - STOP VALVE	ASSEMBLY	1

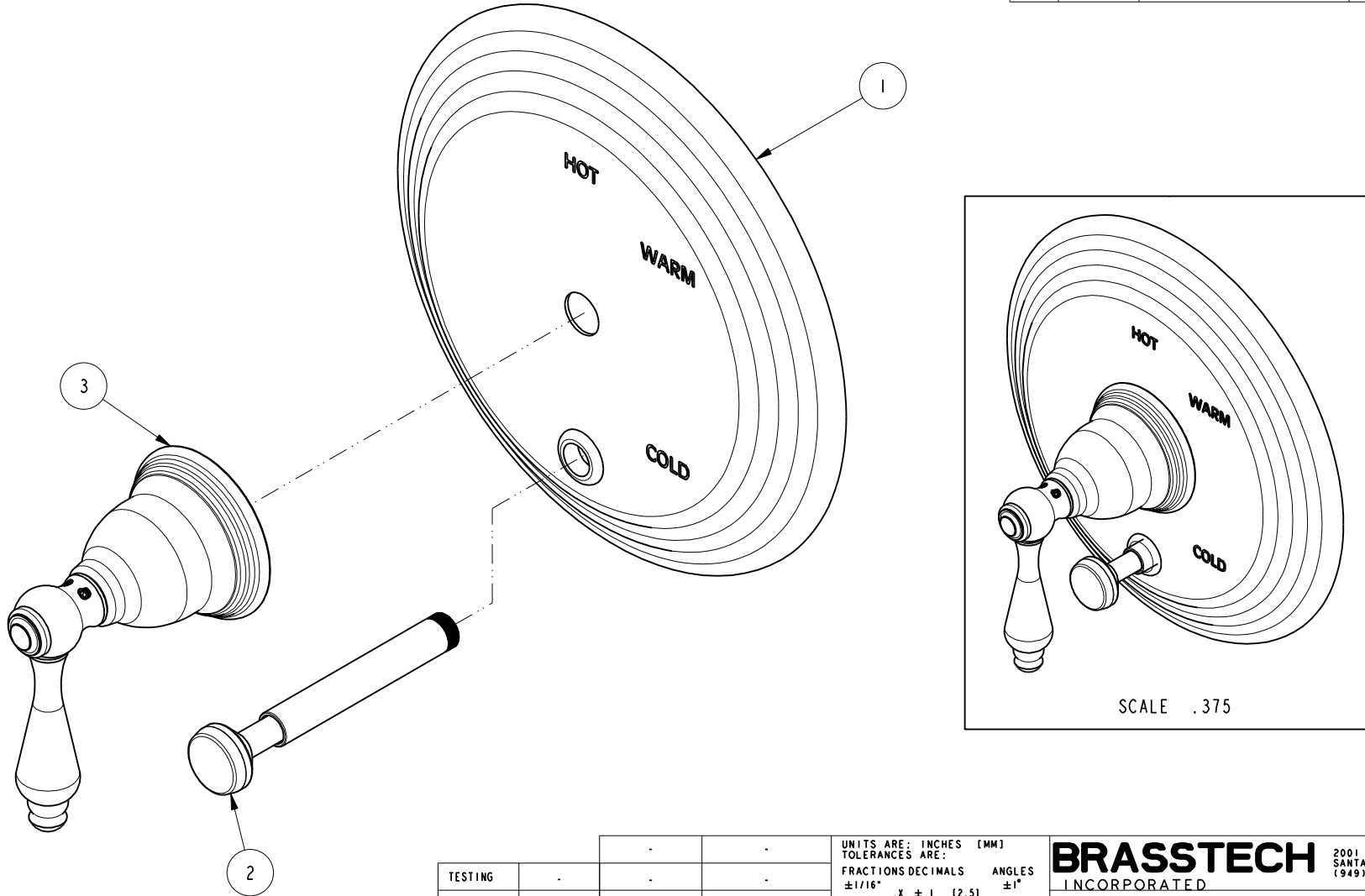

ZONE	REV	DESCRIPTION	DATE	APPROVED
-	B	EN-4300e	04/28/21	R.S.
-	A	EN-2997	08/25/16	J.A.
-	-	EN-2735	04/30/14	-

COPYRIGHT 2005 BRASSTECH, INC. THESE DRAWINGS AND THE DESIGNS DEPICTED HEREIN ARE THE PROPRIETARY PROPERTY OF BRASSTECH. ANY USE OR REPRODUCTION IS SUBJECT TO THE EXPRESS APPROVAL OF BRASSTECH. UNAUTHORIZED USE IS STRICTLY PROHIBITED. ALL RIGHTS RESERVED.

TESTING	-	-	-
ASSEMBLY	-	-	-
PLATING	-	-	-
POLISHING	-	NEXT ASSY	USED ON
MACHINING	-	APPLICATION	
TOOLING FIXTURE #	REMOVE ALL BURRS AND SHARP EDGES		

UNITS ARE: INCHES [MM]	
TOLERANCES ARE:	
FRACTIONS	DECIMALS ANGLES
±1/16"	.X ±.1 [2.5] ±1°
	.XX ±.06 [1.5]
(X.XXX) DENOTES CRITICAL DIMS. ALL THREADS ARE CRITICAL	
DRAWN	JINSON 04/28/21
CHECKED	R.S. 04/28/21
APPROVED	R.S. 04/28/21

**BRASSTECH** 2001 CARNEGIE AVE. SANTA ANA, CA 92705 (949) 417-5207  
INCORPORATED

**BP TRIM PLATE WITH DIVERTER**

DWG NO. **5-852BP** REV **B**

SCALE .500 REF. - SHEET 1 OF 2

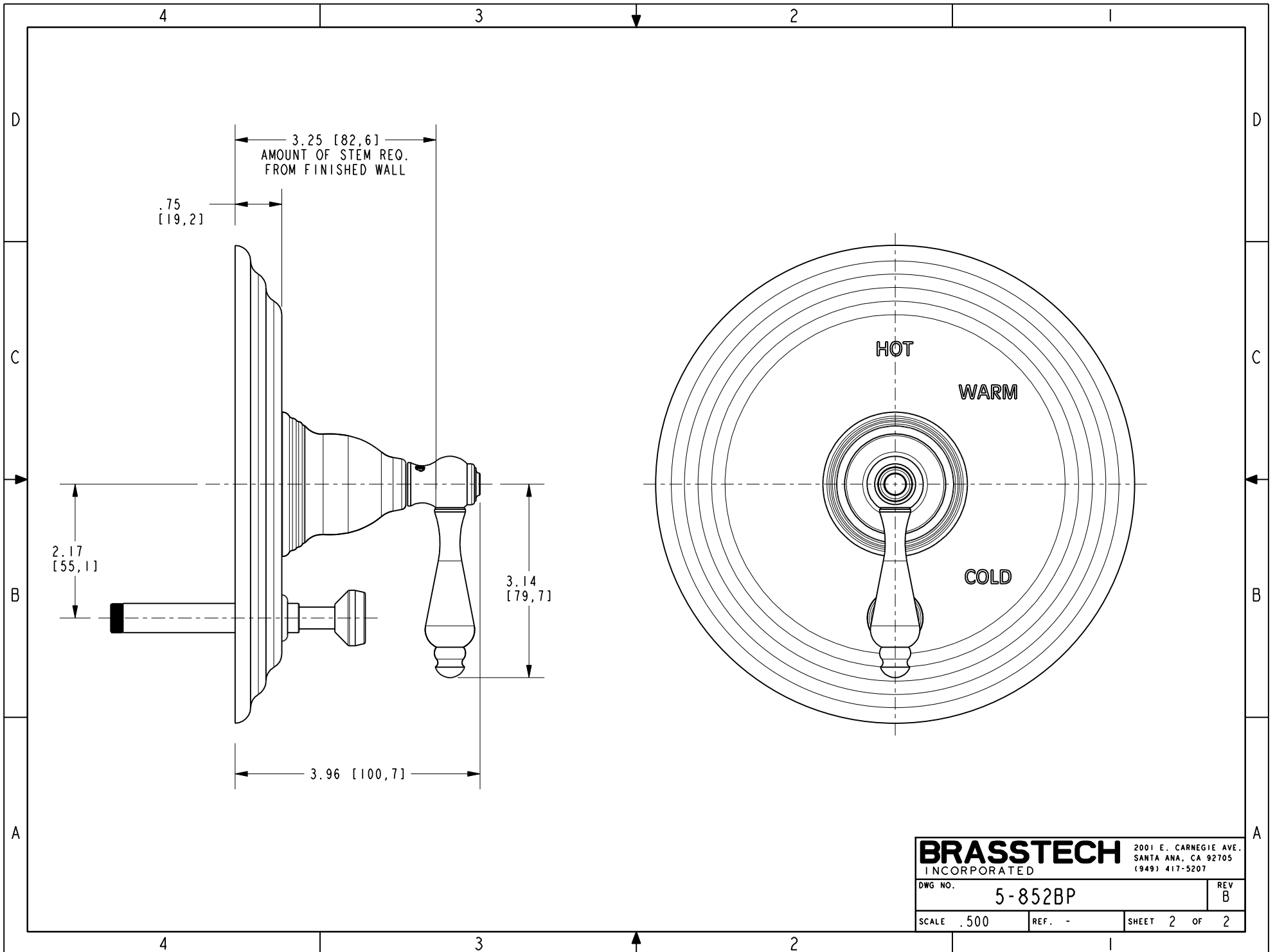

<b>BRASSTECH</b>		2001 E. CARNEGIE AVE.
INCORPORATED		SANTA ANA, CA 92705
		(949) 417-5207
DWG NO.	5-852BP	REV B
SCALE .500	REF. -	SHEET 2 OF 2