

NOTES:

1. TO INSPECT ASSEMBLY, FOLLOW FIRST ARTICLE AND IN PROCESS INSPECTION SHEET.

2. APPLY ADHESIVE LOCTITE 680 OR EQUIVALENT.

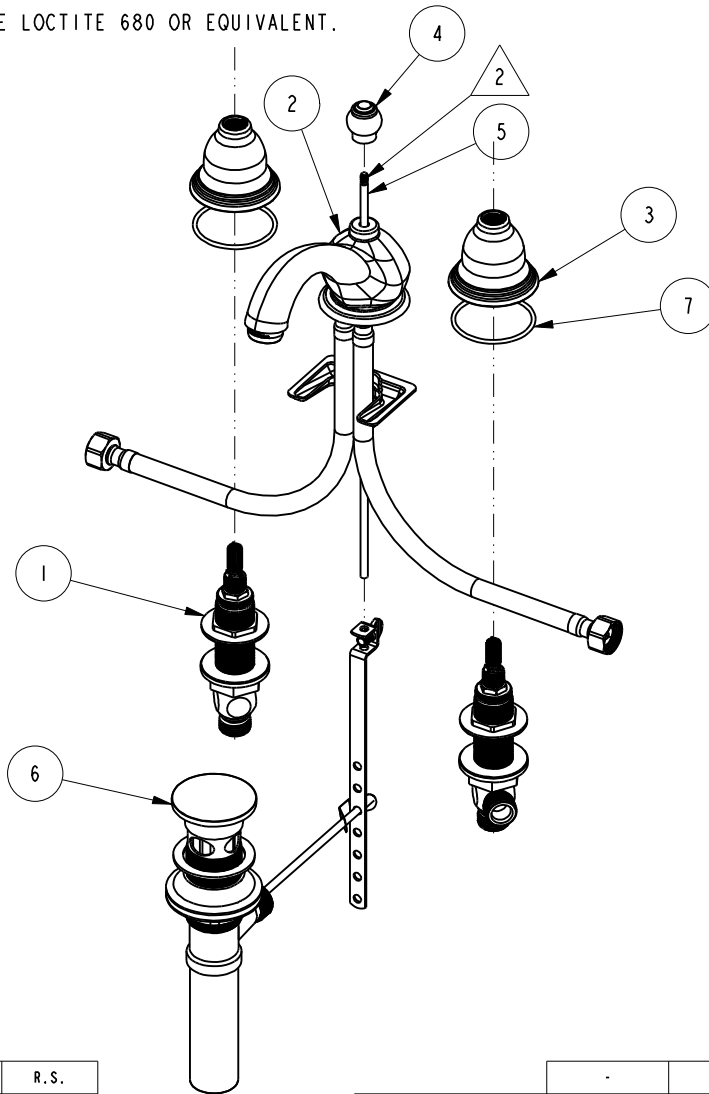

BILL OF MATERIAL (CURRENT LEVEL)

ITEM	PT/ASSY	DESCRIPTION	TYPE	QTY.
1	1-525	W/S VALVE ASM	ASSEMBLY	1
2	3-365	SPOUT ASM	ASSEMBLY	1
3	10016	ESCUTCHEON BELL	PART	2
4	10010	POP-UP KNOB	PART	1
5	10288	3/16" POP UP ROD	PART	1
6	325	POP UP ASSEMBLY	ASSEMBLY	1
7	91753	O-RING, # 2-136, EP, 50 DURO - GREY	PART	2

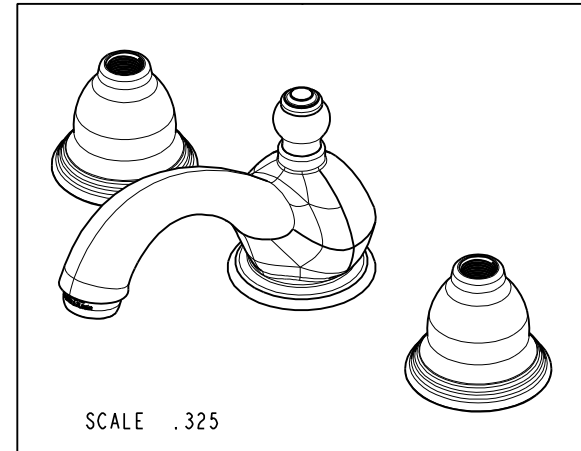

ZONE	REV	DESCRIPTION	DATE	APPROVED
-	H	EN-4300m	11/10/20	R.S.
-	G	EN-3722	02/08/19	C.G.
-	F	EN-2348b	12/19/13	-
-	E	EN-1616	09/13/10	-
-	D	EN-1262	06/03/09	-
-	C	EO-0122	12/17/02	-

COPYRIGHT 2005 BRASSTECH, INC. THESE DRAWINGS AND THE DESIGNS DEPICTED HEREIN ARE THE PROPRIETARY PROPERTY OF BRASSTECH. ANY USE OR REPRODUCTION IS SUBJECT TO THE EXPRESS APPROVAL OF BRASSTECH. UNAUTHORIZED USE IS STRICTLY PROHIBITED. ALL RIGHTS RESERVED.

TESTING	ASSEMBLY	PLATING	POLISHING	MACHINING	TOOLING FIXTURE #	APPLICATION
-	-	-	-	-	-	REMOVE ALL BURRS AND SHARP EDGES
-	-	-	-	-	-	USED ON
-	-	-	-	-	-	NEXT ASSY

UNITS ARE: INCHES [MM]		
TOLERANCES ARE:		
FRACTIONS	DECIMALS	ANGLES
±1/16"	.X ±.1 [2.5]	±°
	.XX ±.06 [1.5]	
(X.XXX) DENOTES CRITICAL DIMS.		
ALL THREADS ARE CRITICAL		
DRAWN	JINSON	11/10/20
CHECKED	R.S.	11/10/20
APPROVED	R.S.	11/10/20

BRASSTECH 2001 CARNEGIE AVE. SANTA ANA, CA 92705 (949) 417-5207
INCORPORATED

WIDESPREAD

DWG NO. **7000** REV **H**

SCALE .200 REF. - SHEET 1 OF 2

