

NOTES:

1. TO INSPECT ASSEMBLY, FOLLOW FIRST ARTICLE AND IN PROCESS INSPECTION SHEET.

2. AFFIX LABEL 98144, ITEM 3, UNDERNEATH THE SPOUT, CENTERED, APPROX. WHERE SHOWN.

BILL OF MATERIAL (CURRENT LEVEL)

ITEM	PT/ASSY	DESCRIPTION	TYPE	QTY.
1	3-530	W/S LAVATORY FAUCET	ASSEMBLY	1
2	1-691	W/S VALVE ASM	ASSEMBLY	1
3	98144	NEWPORT BRASS LABEL	PART	1

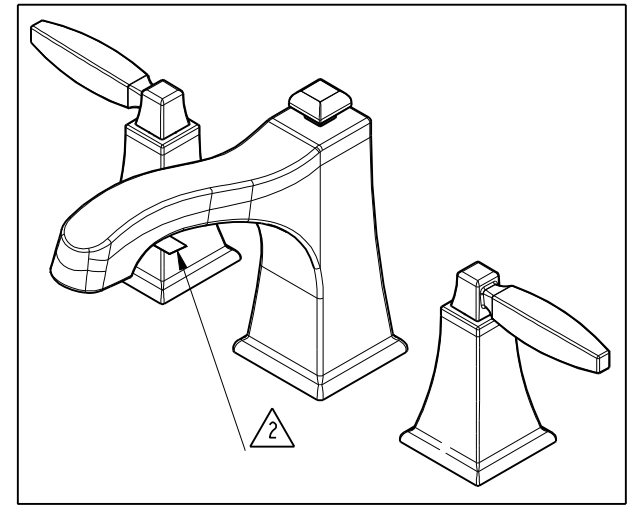
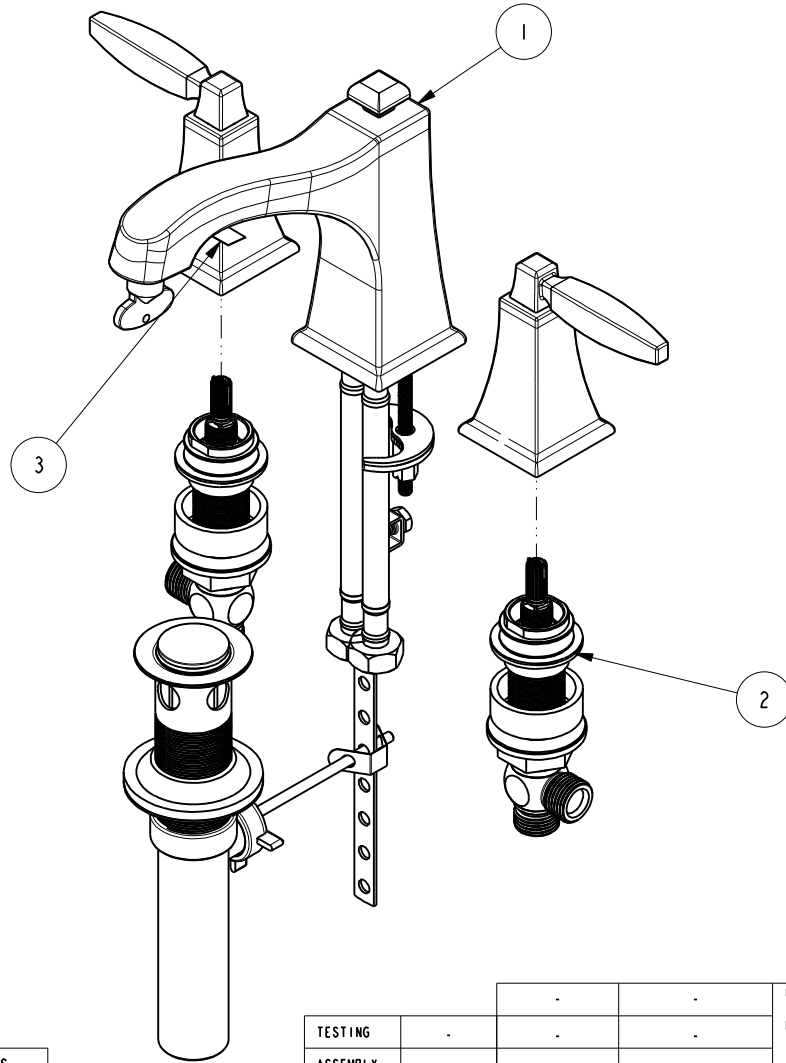

ZONE	REV	DESCRIPTION	DATE	APPROVED
-	C	EN-4300m	11/12/20	R.S.
-	B	EN-3260	03/09/17	NS
-	A	EN-3010	02/19/16	V.V.
-	-	EN-2741	08/27/14	V.V.

COPYRIGHT 2005 BRASSTECH, INC. THESE DRAWINGS AND THE DESIGNS DEPICTED HEREIN ARE THE PROPRIETARY PROPERTY OF BRASSTECH. ANY USE OR REPRODUCTION IS SUBJECT TO THE EXPRESS APPROVAL OF BRASSTECH. UNAUTHORIZED USE IS STRICTLY PROHIBITED. ALL RIGHTS RESERVED.

TESTING	-	-	-
ASSEMBLY	-	-	-
PLATING	-	-	-
POLISHING	-	NEXT ASSY	USED ON
MACHINING	-	APPLICATION	
TOOLING FIXTURE #	REMOVE ALL BURRS AND SHARP EDGES		

UNITS ARE: INCHES [MM]		
TOLERANCES ARE:		
FRACTIONS	DECIMALS	ANGLES
±1/16"	.X ±.1 (2.5)	±1°
	.XX ±.06 (1.5)	
(X.XXX) DENOTES CRITICAL DIMS. ALL THREADS ARE CRITICAL		
DRAWN	JINSON	11/12/20
CHECKED	R.S.	11/12/20
APPROVED	R.S.	11/12/20

**BRASSTECH** 2001 CARNEGIE AVE. SANTA ANA, CA 92705 (949) 417-5207  
INCORPORATED

**WIDESPREAD LAVATORY FAUCET**

DWG NO. **8100** REV **C**

SCALE .290 REF. - SHEET 1 OF 2

