

NOTES:

1. TO INSPECT ASSEMBLY, FOLLOW FIRST ARTICLE AND IN PROCESS INSPECTION SHEET.

2. AFFIX LABEL 98144, ITEM 3, BEHIND THE SPOUT, CENTERED, APPROX. WHERE SHOWN.

BILL OF MATERIAL (CURRENT LEVEL)

| ITEM | PT/ASSY | DESCRIPTION | TYPE | QTY. |
|------|---------|---------------------|----------|------|
| 1 | 1-713 | W/S VALVE ASM | ASSEMBLY | 1 |
| 2 | 3-526 | W/S LAVATORY FAUCET | ASSEMBLY | 1 |
| 3 | 98144 | NEWPORT BRASS LABEL | PART | 1 |

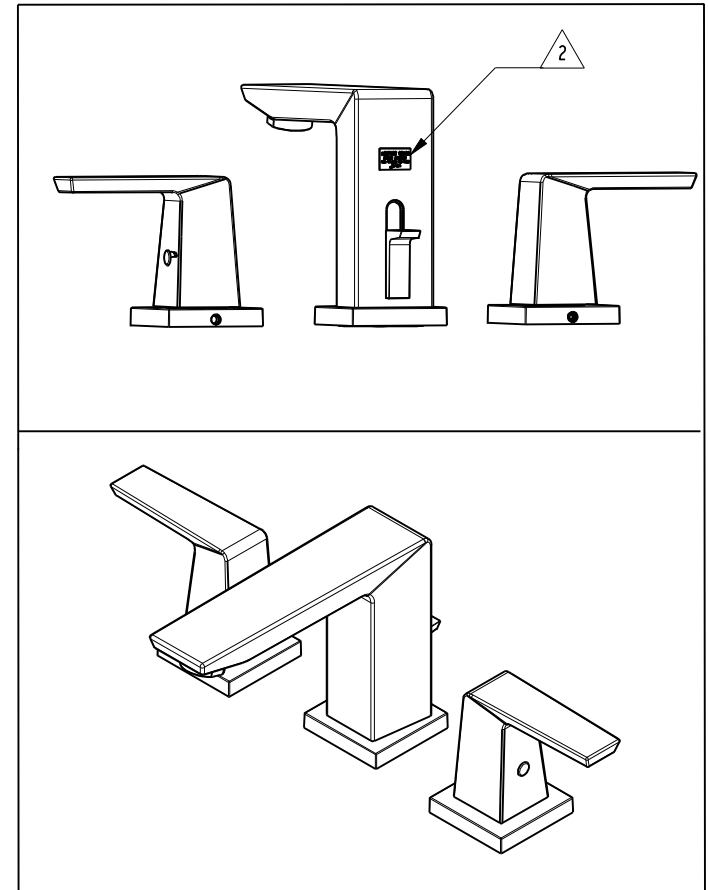
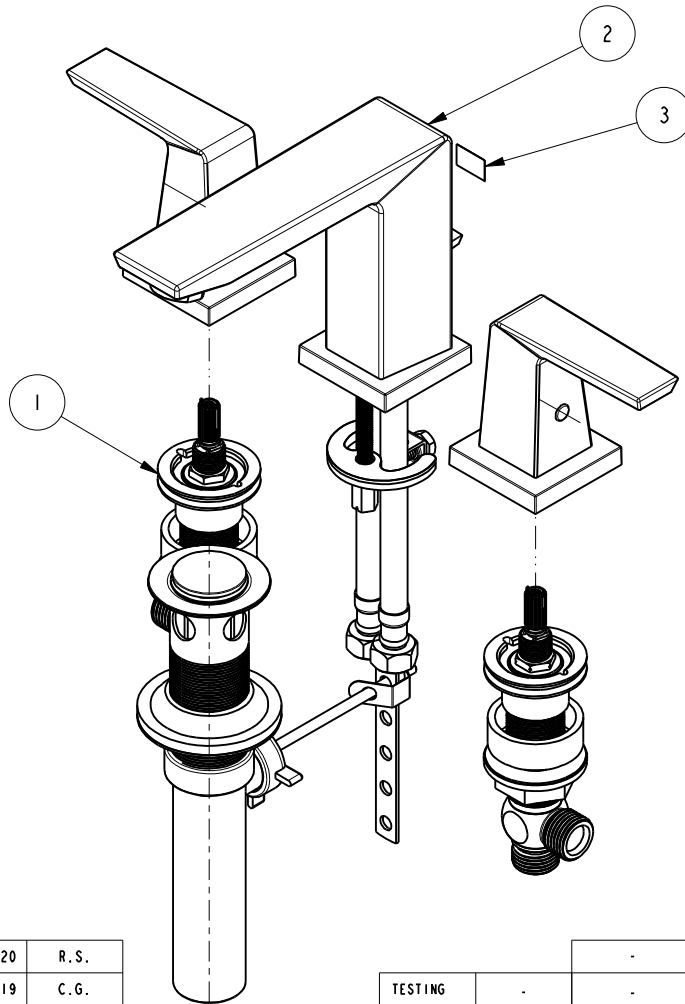

| ZONE | REV | DESCRIPTION | DATE | APPROVED |
|------|-----|-------------|----------|----------|
| - | E | EN-4300m | 11/12/20 | R.S. |
| - | D | EN-4001 | 10/16/19 | C.G. |
| - | C | EN-3843 | 05/06/19 | V.V. |
| - | B | EN-3260 | 03/10/17 | NS |
| - | A | EN-3010 | 02/19/16 | V.V. |
| - | - | EN-2741 | 08/27/14 | V.V. |

COPYRIGHT 2005 BRASSTECH, INC. THESE DRAWINGS AND THE DESIGNS DEPICTED HEREIN ARE THE PROPRIETARY PROPERTY OF BRASSTECH. ANY USE OR REPRODUCTION IS SUBJECT TO THE EXPRESS APPROVAL OF BRASSTECH. UNAUTHORIZED USE IS STRICTLY PROHIBITED. ALL RIGHTS RESERVED.

| TESTING | ASSEMBLY | PLATING | POLISHING | MACHINING | TOOLING FIXTURE # | APPLICATION |
|---------|----------|---------|-----------|-----------|-------------------|----------------------------------|
| - | - | - | - | - | - | REMOVE ALL BURRS AND SHARP EDGES |
| - | - | - | - | - | - | USED ON |
| - | - | - | - | - | - | NEXT ASSY |

UNITS ARE: INCHES [MM]
TOLERANCES ARE:
FRACTIONS DECIMALS ANGLES
±1/16" .X ±.1 [2.5] ±1°
.XX ±.06 [1.5]

(X.XXX) DENOTES CRITICAL DIMS.
ALL THREADS ARE CRITICAL

| DRAWN | CHECKED | APPROVED |
|----------|----------|----------|
| JINSON | R.S. | R.S. |
| 11/12/20 | 11/12/20 | 11/12/20 |

BRASSTECH 2001 CARNEGIE AVE.
INCORPORATED SANTA ANA, CA 92705
(949) 417-5207

WIDESPREAD LAVATORY FAUCET

| DWG NO. | SCALE | REF. | SHEET | OF |
|---------|-------|------|-------|----|
| 8300 | .250 | - | 1 | 2 |

REV
E

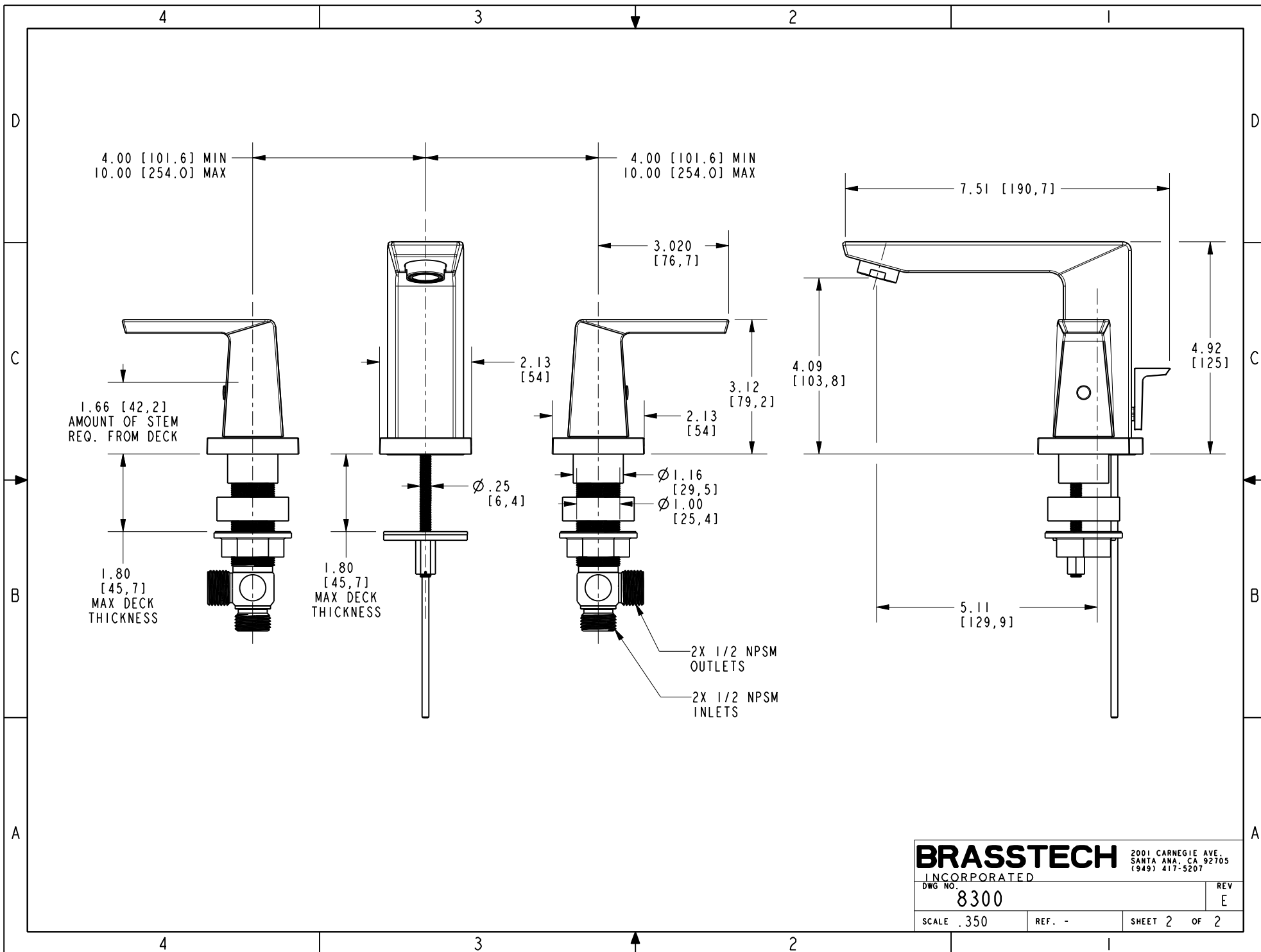

BRASSTECH 2001 CARNEGIE AVE.
INCORPORATED SANTA ANA, CA 92705
(949) 417-5207

DWG NO. 8300 REV E

SCALE .350 REF. - SHEET 2 OF 2