

NOTES:

1. TO INSPECT ASSEMBLY, FOLLOW FIRST ARTICLE AND IN PROCESS INSPECTION SHEET.

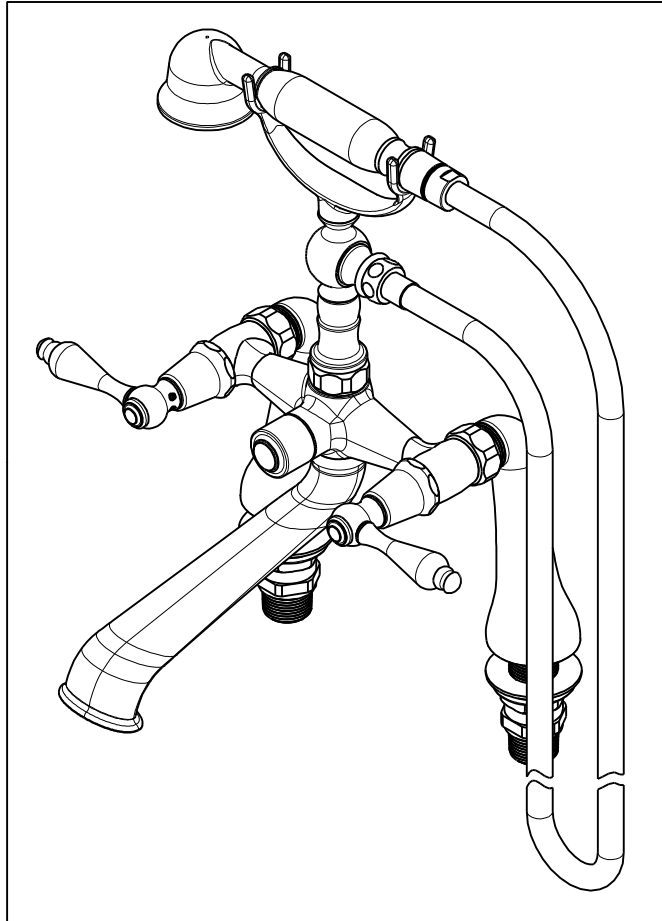

BILL OF MATERIAL (CURRENT LEVEL)

ITEM	PT/ASSY	DESCRIPTION	TYPE	QTY.
1	12894	BODY - FOR 933,934	PART	1
2	2-220	RISER ASM	ASSEMBLY	1
3	284_	59 IN. SPIRAL SHOWER HOSE	ASSEMBLY	1
4	281	HANDSHOWER ASM	ASSEMBLY	1
5	12585	SPOUT	PART	1
6	91022	O-RING, #2- 018, EPDM, 65-75 DURO, NSF 61	PART	1
7	1-326	W/S CARTRIDGE FRICTION - HOT	PART	1
8	1-325	W/S CARTRIDGE FRICTION - COLD	PART	1
9	12259	HANDLE BONNET - TUB FILLER	PART	2
10	12062	ADAPTER - 20-T X 16-T	PART	2
11	92539	SCRW, M4X22 FLAT HD SOCKET HD CAP	PART	2
12	2-116	LEVER HANDLE (BRASS)	ASSEMBLY	2
13	10442	SEAT FOR CARTRIDGE	PART	2
14	91020	O-RING, #2-016, EPDM, 65-75 DURO, NSF 61	PART	2
15	10332	HEX NUT	PART	2
16	91039	WSHR, .625 ID X 1.00 OD X .125 THK, RUBBER	PART	2
17	10336	LEG - LEFT	PART	1
18	10335	LEG - RIGHT	PART	1
19	1-049	MOUNTING HARDWARE	ASSEMBLY	1
20	20-260	DIVERTER ASM	ASSEMBLY	1
21	20-259	DIVERTER ASM	ASSEMBLY	1
22	13313	DIVERTER BUTTON	PART	1

-	H	EN-4300h	01/05/21	R.S.
-	G	EN-3565A	01/22/20	C.G.
-	F	EN-3488	12/08/17	J.M.
-	E	EN-3447	10/27/17	V.V.
-	D	EN-3150o	05/18/17	J.M.
-	C	EN-3224	01/03/17	AN
-	B	EN-3160	10/25/16	J.M.
-	A	EN-2818	11/20/14	AN
-	-	EN-2606	04/14/14	AN
ZONE	REV	DESCRIPTION	DATE	APPROVED

COPYRIGHT 2005 BRASSTECH, INC. THESE DRAWINGS AND THE DESIGNS DEPICTED HEREIN ARE THE PROPRIETARY PROPERTY OF BRASSTECH. ANY USE OR REPRODUCTION IS SUBJECT TO THE EXPRESS APPROVAL OF BRASSTECH. UNAUTHORIZED USE IS STRICTLY PROHIBITED. ALL RIGHTS RESERVED.

TESTING	-	-	-
ASSEMBLY	-	-	-
PLATING	-	-	-
POLISHING	-	NEXT ASSY	USED ON
MACHINING	-	APPLICATION	
TOOLING FIXTURE #	REMOVE ALL BURRS AND SHARP EDGES		

UNITS ARE: INCHES [MM]
TOLERANCES ARE:
FRACTIONS DECIMALS ANGLES
±1/16" .X ±.1 [2,5] ±°
.XX ±.06 [1,5]

(X.XXX) DENOTES CRITICAL DIMS.
ALL THREADS ARE CRITICAL

DRAWN	JINSON	01/05/21
CHECKED	R.S.	01/05/21
APPROVED	R.S.	01/05/21

BRASSTECH 2001 CARNEGIE AVE.
INCORPORATED SANTA ANA, CA 92705
(949) 417-5207

EXPOSED TUB FILLER, DECK MOUNT

DWG NO.	850-4273	REV	H
SCALE	.250	REF.	-
SHEET	1	OF	3

- △ 2. APPLY ADHESIVE LOCTITE 680.
- △ 3. TORQUE TO 15-20 FT-LB.
- △ 4. APPLY LOCTITE 242 IF SCREW DOES NOT HAVE NYLON PATCH.
- △ 5. TORQUE TO 11-14 FT-LB.

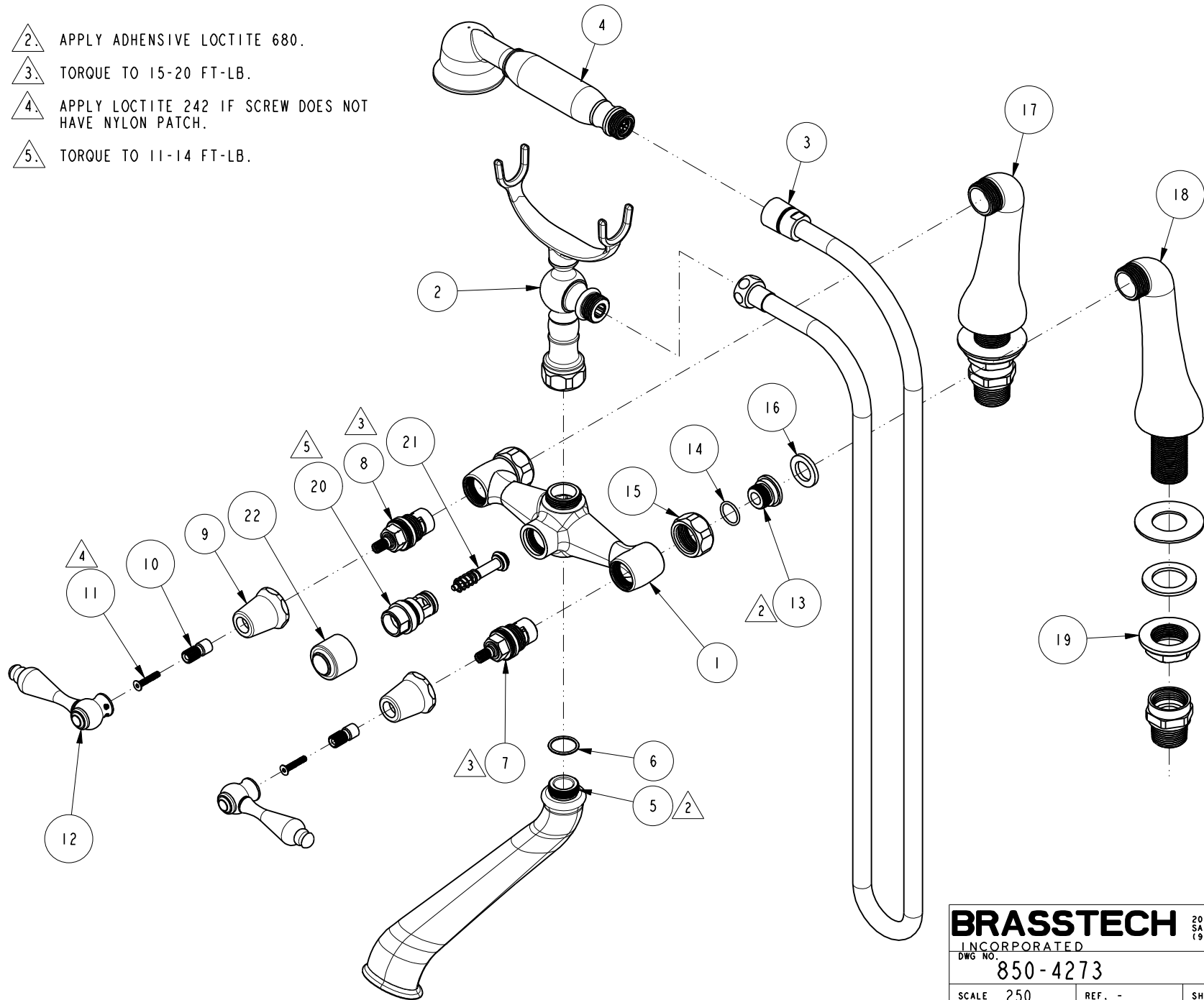

BRASSTECH 2001 CARNEGIE AVE.
 INCORPORATED SANTA ANA, CA 92705
 (949) 417-5207

DWG NO.	850-4273	REV	H
SCALE	.250	REF.	-
		SHEET	2 OF 3

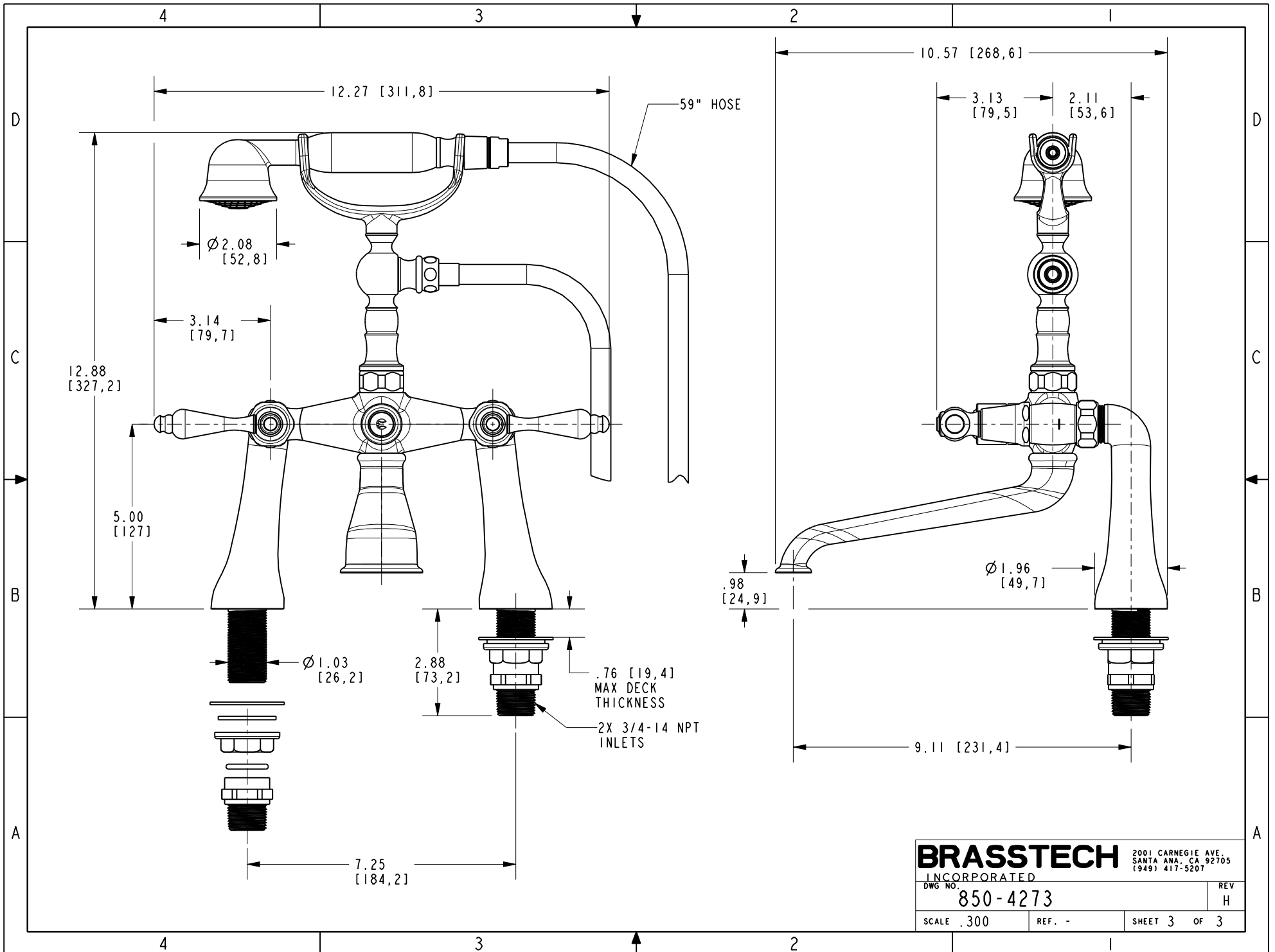

BRASSTECH 2001 CARNEGIE AVE.
 INCORPORATED SANTA ANA, CA 92705
 (949) 417-5207

DWG NO. 850-4273 REV H

SCALE .300 REF. - SHEET 3 OF 3