

NOTES:

1. TO INSPECT ASSEMBLY, FOLLOW FIRST ARTICLE AND IN PROCESS INSPECTION SHEET.

BILL OF MATERIAL (CURRENT LEVEL)

ITEM	PT/ASSY	DESCRIPTION	TYPE	QTY.
1	1-525	W/S VALVE ASM	ASSEMBLY	1
2	3-348	W/S SPOUT ASM	ASSEMBLY	1
3	10288	3/16" POP UP ROD	PART	1
4	10021	POP-UP KNOB	PART	1
5	325	POP UP ASSEMBLY	ASSEMBLY	1
6	3-202	TRIM KIT - STOP VALVE	ASSEMBLY	2

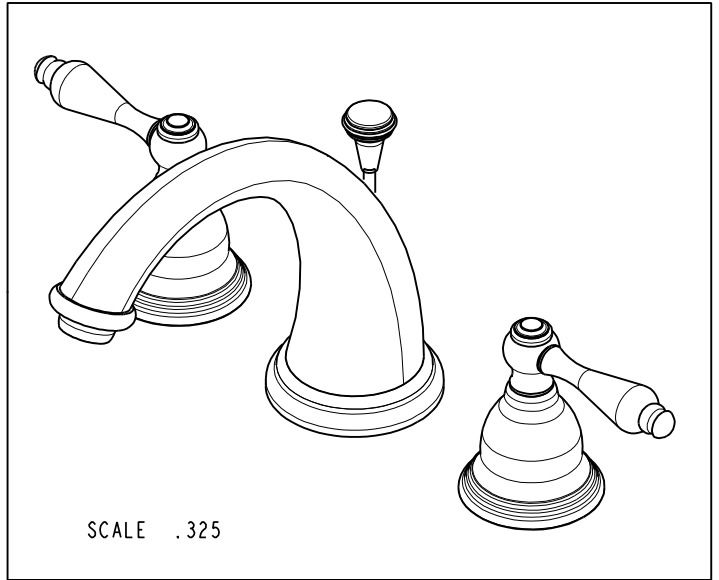
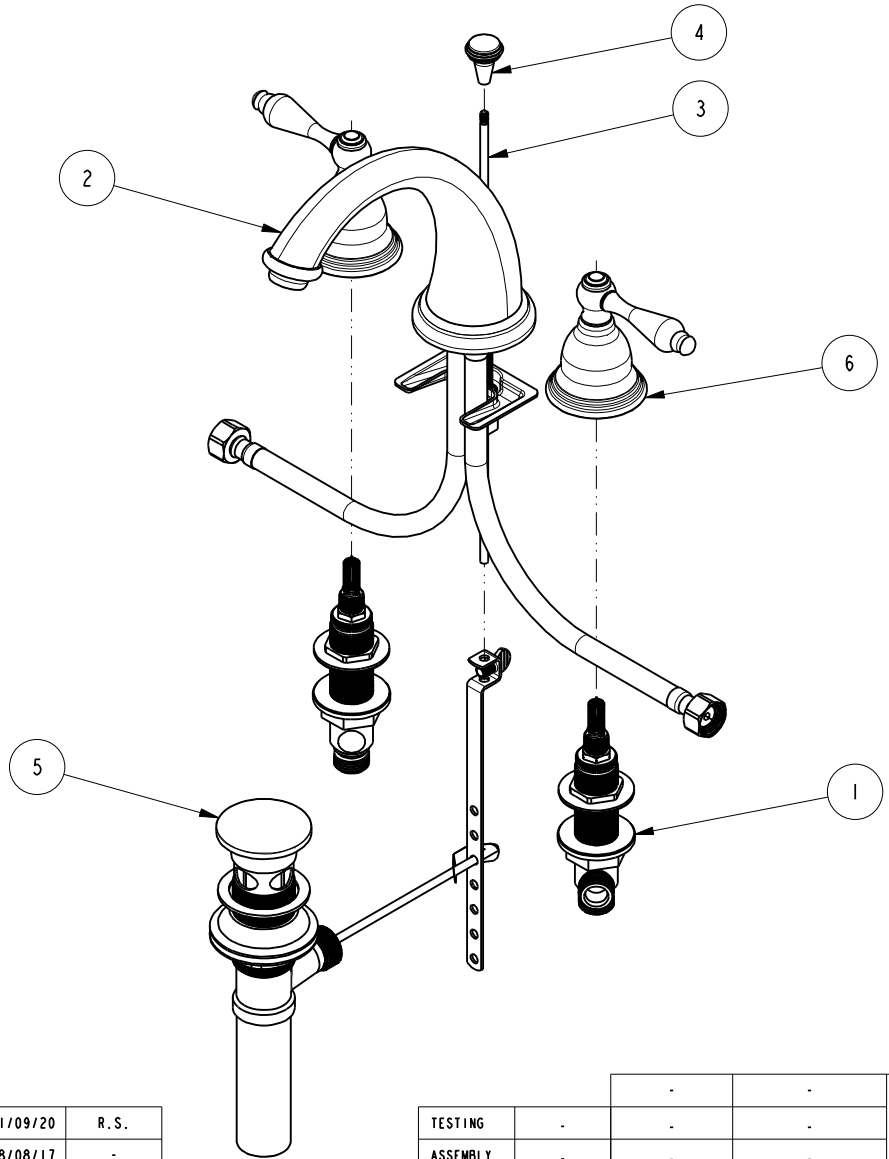

ZONE	REV	DESCRIPTION	DATE	APPROVED
-	D	EN-4300m	11/09/20	R.S.
-	C	EN-3371B	08/08/17	-
-	B	EN-2553	07/01/13	-
-	A	EO-1018	06/10/08	-
-	-	EO-0859	07/19/07	-

COPYRIGHT 2005 BRASSTECH, INC. THESE DRAWINGS AND THE DESIGNS DEPICTED HEREIN ARE THE PROPRIETARY PROPERTY OF BRASSTECH. ANY USE OR REPRODUCTION IS SUBJECT TO THE EXPRESS APPROVAL OF BRASSTECH. UNAUTHORIZED USE IS STRICTLY PROHIBITED. ALL RIGHTS RESERVED.

TESTING	ASSEMBLY	PLATING	POLISHING	MACHINING	TOOLING FIXTURE #	APPLICATION
-	-	-	-	-	-	REMOVE ALL BURRS AND SHARP EDGES
-	-	-	-	-	-	USED ON
-	-	-	-	-	-	APPLICATION

UNITS ARE: INCHES [MM]	
TOLERANCES ARE:	
FRACTIONS	DECIMALS
±1/16"	.X ±.1 [2,5]
	.XX ±.06 [1,5]
ANGLES ±°	
(X.XXX) DENOTES CRITICAL DIMS.	
ALL THREADS ARE CRITICAL	
DRAWN	JINSON
CHECKED	R.S.
APPROVED	R.S.

BRASSTECH 2001 CARNEGIE AVE. SANTA ANA, CA 92705 (949) 417-5207
INCORPORATED

WIDESPREAD FAUCET

DWG NO. **850C** REV **D**

SCALE .225 REF. - SHEET 1 OF 2

