

NOTES:

1. TO INSPECT ASSEMBLY, FOLLOW FIRST ARTICLE AND IN PROCESS INSPECTION SHEET.

BILL OF MATERIAL (CURRENT LEVEL)

ITEM	PT/ASSY	DESCRIPTION	TYPE	QTY.
1	1-525	W/S VALVE ASM	ASSEMBLY	1
2	3-356	WIDESPREAD SPOUT ASM	ASSEMBLY	1
3	3-159	TRIM KIT - STOP VALVE	ASSEMBLY	2
4	10288	3/16" POP UP ROD	PART	1
5	10104	KNOB POP-UP 880 SERIES	PART	1
6	325	POP UP ASSEMBLY	ASSEMBLY	1

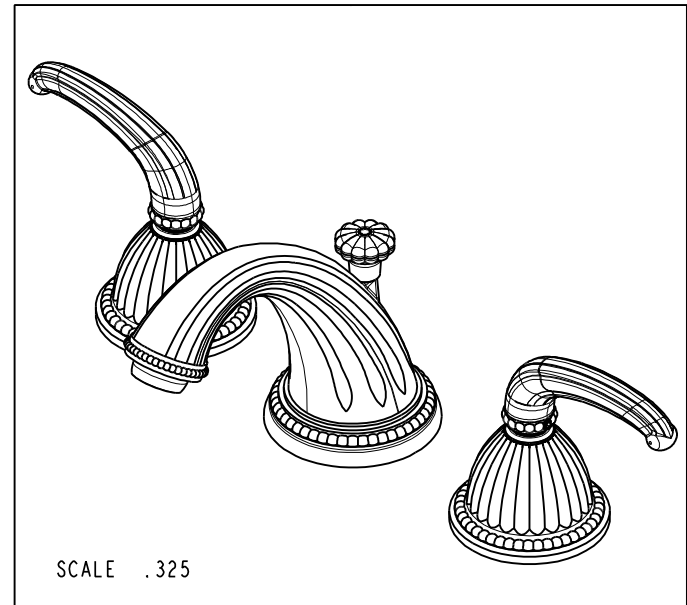
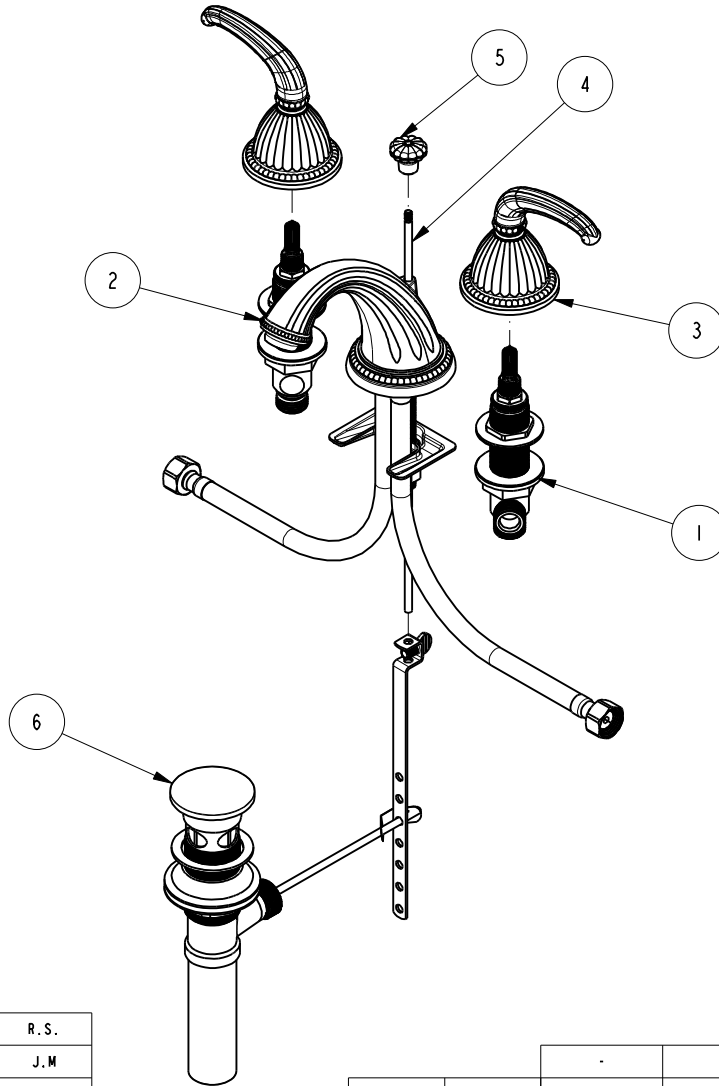

-	H	EN-4300m	10/29/20	R.S.
-	G	EN-3371	08/04/17	J.M
-	F	EN-2929	07/29/15	-
-	E	EN-2553	07/01/13	-
-	D	EN-1616	09/13/10	-
-	C	EO-1020	06/10/08	-
-	B	SPOUT CHG	1998	-
ZONE	REV	DESCRIPTION	DATE	APPROVED

COPYRIGHT 2005 BRASSTECH, INC. THESE DRAWINGS AND THE DESIGNS DEPICTED HEREIN ARE THE PROPRIETARY PROPERTY OF BRASSTECH. ANY USE OR REPRODUCTION IS SUBJECT TO THE EXPRESS APPROVAL OF BRASSTECH. UNAUTHORIZED USE IS STRICTLY PROHIBITED. ALL RIGHTS RESERVED.

TESTING	-	-	-
ASSEMBLY	-	-	-
PLATING	-	-	-
POLISHING	-	NEXT ASSY	USED ON
MACHINING	-	APPLICATION	
TOOLING FIXTURE #	REMOVE ALL BURRS AND SHARP EDGES		

UNITS ARE: INCHES [MM]	
TOLERANCES ARE:	
FRACTIONS DECIMALS	ANGLES
±1/16"	±°
.X ±.1 [2.5]	
.XX ±.06 [1.5]	
(X.XXX) DENOTES CRITICAL DIMS. ALL THREADS ARE CRITICAL	
DRAWN	JINSON 11/10/20
CHECKED	R.S. 11/10/20
APPROVED	R.S. 11/10/20

BRASSTECH 2001 CARNEGIE AVE. SANTA ANA, CA 92705 (949) 417-5207
INCORPORATED

WIDESPREAD FAUCET

DWG NO. **880** REV **H**

SCALE .200 REF. - SHEET 1 OF 2

