

NOTES:

1. TO INSPECT ASSEMBLY, FOLLOW FIRST ARTICLE AND IN PROCESS INSPECTION SHEET.

BILL OF MATERIAL (CURRENT LEVEL)

ITEM	PT/ASSY	DESCRIPTION	TYPE	QTY.
1	1-107	COLD BUTTON ASSEMBLY W/ ADHESIVE	ASSEMBLY	1
2	1-108	HOT BUTTON ASSEMBLY W/ ADHESIVE	ASSEMBLY	1
3	2-132	BAR SPOUT ASM	ASSEMBLY	1
4	2-173	CROSS HANDLE ASSEMBLY W/O BUTTON	ASSEMBLY	2
5	2-761	SINGLE HOLE CROSS BAR ASSEMBLY	ASSEMBLY	1
6	10331	BONNET FOR 933, 934	PART	2

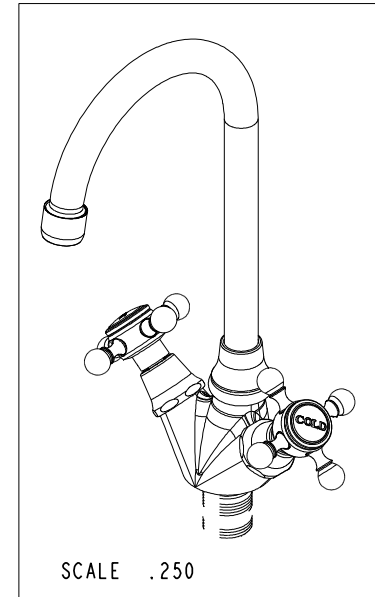
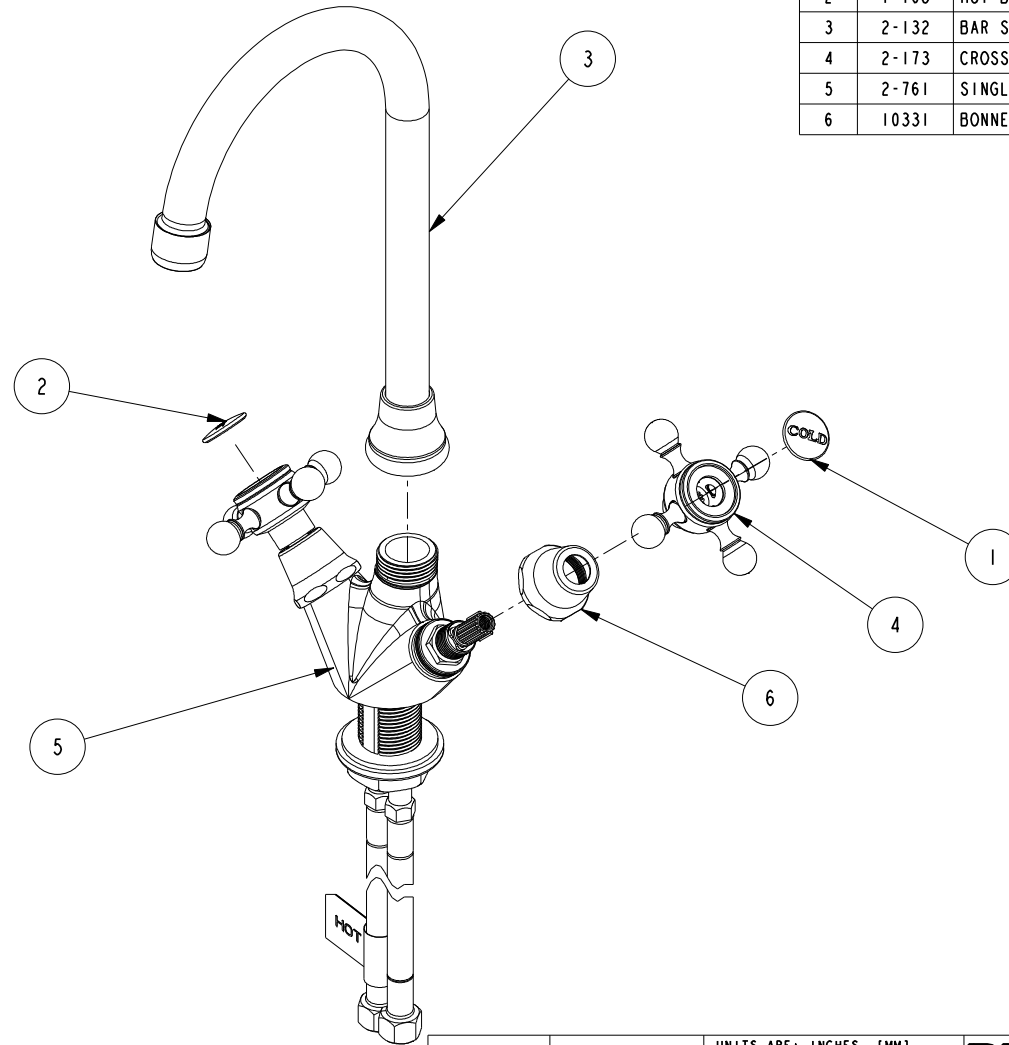

-	F	EN-4300hh	04/12/21	R.S.
-	D	EN-2643	01/15/16	J.M
-	C	EN-2119	07/17/12	-
-	B	EN-1728	04/26/11	-
-	A	EO-0129	08/02/06	-
-	-	RELEASE	PRE '95	-
ZONE	REV	DESCRIPTION	DATE	APPROVED

COPYRIGHT 2005 BRASSTECH, INC. THESE DRAWINGS AND THE DESIGNS DEPICTED HEREIN ARE THE PROPRIETARY PROPERTY OF BRASSTECH. ANY USE OR REPRODUCTION IS SUBJECT TO THE EXPRESS APPROVAL OF BRASSTECH. UNAUTHORIZED USE IS STRICTLY PROHIBITED. ALL RIGHTS RESERVED.

TESTING	-	-	-
ASSEMBLY	-	-	-
PLATING	-		
POLISHING	-	NEXT ASSY	USED ON
MACHINING	-	APPLICATION	
TOOLING FIXTURE #		REMOVE ALL BURRS AND SHARP EDGES	

UNITS ARE: INCHES [MM]
TOLERANCES ARE:
FRACTIONS DECIMALS ANGLES
±1/16" .X ±.1 [2.5] ±1°
.XX ±.06 [1.5]

(X.XXX) DENOTES CRITICAL DIMS.
ALL THREADS ARE CRITICAL

DRAWN	RAVINDRA	12/28/15
CHECKED	JINSON	12/28/15
APPROVED	J.M	01/15/16

BRASSTECH 2001 CARNEGIE AVE.
INCORPORATED SANTA ANA, CA 92705
(949) 417-5207

BAR FAUCET ASM

DWG NO.	928	REV	E
SCALE	.320	REF.	-
SHEET	1	OF	2

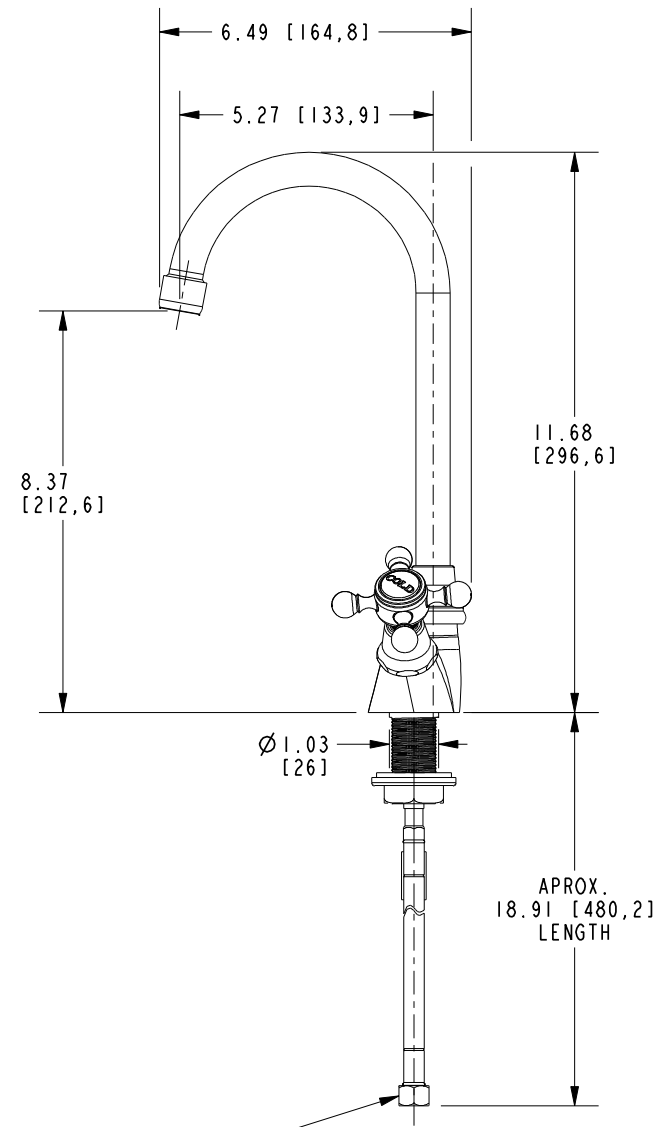
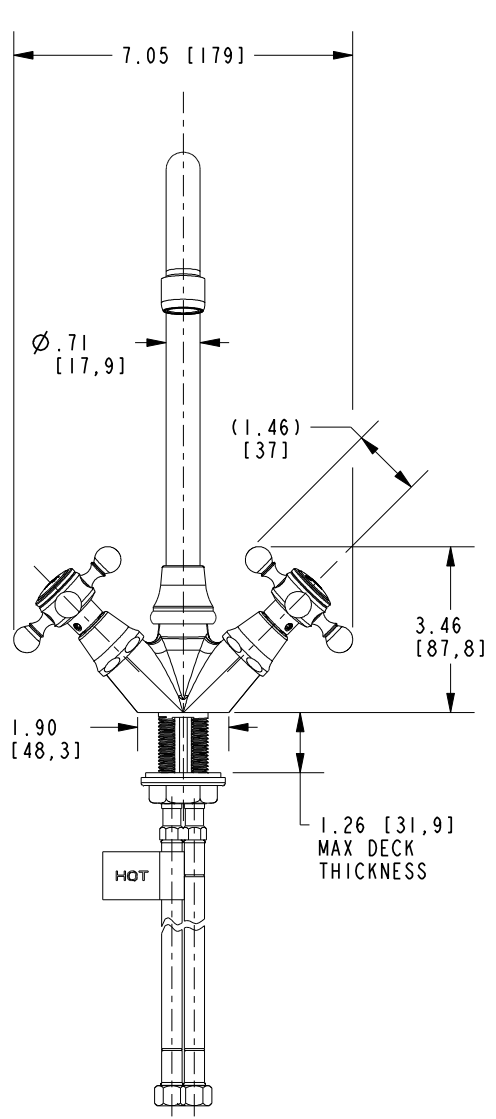

2X 3/8" O.D. COMPRESSION
(9/16-24 UNF THREAD)

BRASSTECH		2001 E. CARNEGIE AVE. SANTA ANA, CA 92705 (949) 417-5207	
DWG NO.	928	REV	E
SCALE	.250	REF.	-
		SHEET	2 OF 2