

NOTES:

1. TO INSPECT ASSEMBLY, FOLLOW FIRST ARTICLE AND IN PROCESS INSPECTION SHEET.

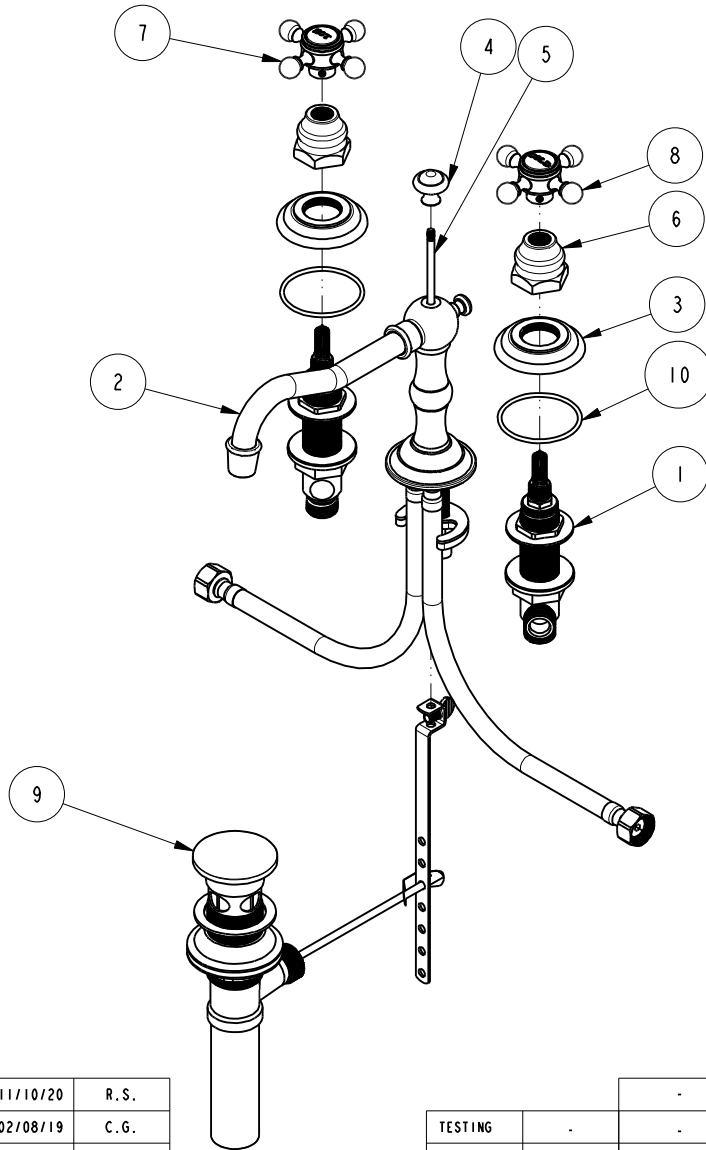

BILL OF MATERIAL (CURRENT LEVEL)

ITEM	PT/ASSY	DESCRIPTION	TYPE	QTY.
1	1-525	W/S VALVE ASM	ASSEMBLY	1
2	3-360	WIDE SPREAD SPOUT ONLY	ASSEMBLY	1
3	10048	ESCUTCHEON W/S VALVE	PART	2
4	10289	POP-UP KNOB	PART	1
5	10288	3/16" POP UP ROD	PART	1
6	10523	HEX ESCUTCHEON BONNET	PART	2
7	2-141	HANDLE ONLY, HOT	ASSEMBLY	1
8	2-142	HANDLE ONLY, COLD	ASSEMBLY	1
9	325	POP UP ASSEMBLY	ASSEMBLY	1
10	91753	O-RING, # 2-136, EP, 50 DURO - GREY	PART	2

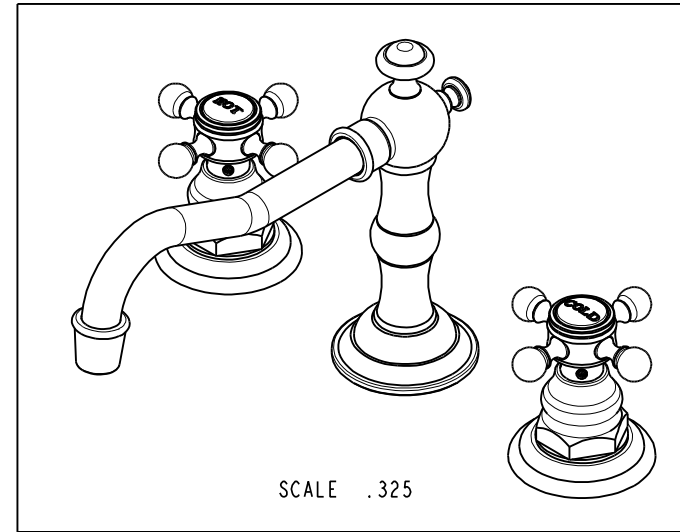

-	G	EN-4300m	11/10/20	R.S.
-	F	EN-3722	02/08/19	C.G.
-	E	EN-2334	12/18/12	-
-	D	EN-1616	09/13/10	-
-	C	EO-1051	07/28/08	-
-	B	EO-0634	01/06/06	-
ZONE	REV	DESCRIPTION	DATE	APPROVED

COPYRIGHT 2005 BRASSTECH, INC. THESE DRAWINGS AND THE DESIGNS DEPICTED HEREIN ARE THE PROPRIETARY PROPERTY OF BRASSTECH. ANY USE OR REPRODUCTION IS SUBJECT TO THE EXPRESS APPROVAL OF BRASSTECH. UNAUTHORIZED USE IS STRICTLY PROHIBITED. ALL RIGHTS RESERVED.

TESTING	-	-	-
ASSEMBLY	-	-	-
PLATING	-	-	-
POLISHING	-	NEXT ASSY	USED ON
MACHINING	-	APPLICATION	
TOOLING FIXTURE #	REMOVE ALL BURRS AND SHARP EDGES		

UNITS ARE: INCHES [MM]		
TOLERANCES ARE:		
FRACTIONS DECIMALS	ANGLES	
±1/16"	±°	
.x ±.1	[2.5]	
.xx ±.06	[1.5]	
(X.XXX) DENOTES CRITICAL DIMS.		
ALL THREADS ARE CRITICAL		
DRAWN	JINSON	11/10/20
CHECKED	R.S.	11/10/20
APPROVED	R.S.	11/10/20

BRASSTECH 2001 CARNEGIE AVE.
INCORPORATED SANTA ANA, CA 92705
(949) 417-5207

WIDESPREAD FAUCET

DWG NO.	930	REV	G
SCALE	.200	REF.	-
SHEET	1	OF	2

