

INSTALLATION INSTRUCTIONS

FREE STANDING TUB FILLERS

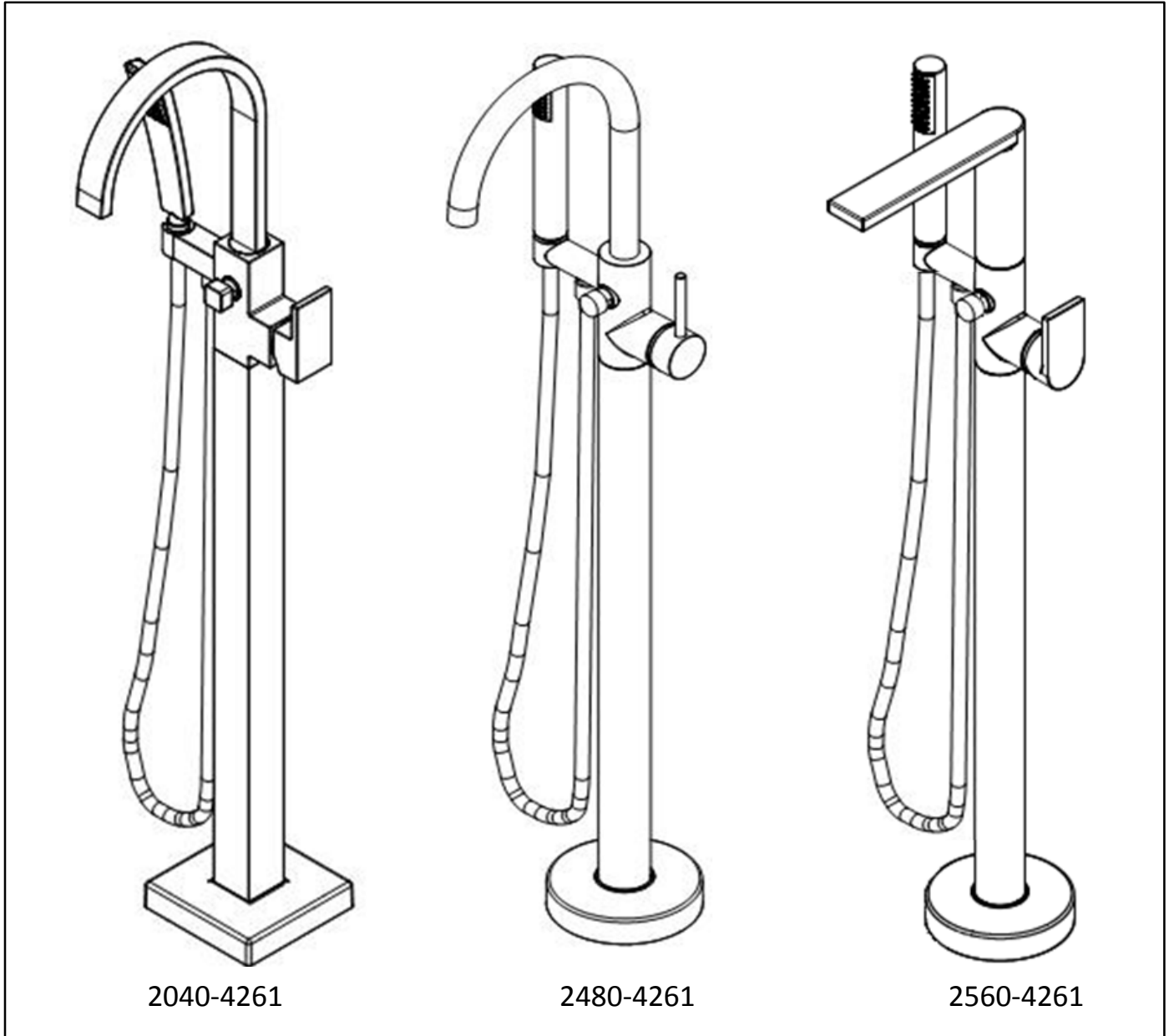

**Congratulations on the purchase of
your Newport Brass product,
an excellent choice that will give you years
of quality service and enhance the look
and style of your home.**

Recommended Installation by a Professional Plumbing Contractor

Important Notes (please read before installing)

Recommended water pressure: 45 to 80 psi

Product is designed to allow for installation in accordance with all national and local plumbing and building codes.

During floor mounting of this product, extra care should be taken while drilling into the floor to avoid damaging any water supply hoses or copper lines that may exist beneath.

CAUTION: To avoid risk of personal injury, do NOT use the tub filler as a support bar to enter or exit the bath. **The tub filler is not designed to support weight.**

Pre-Installation Overview: The Product & Site Preparation

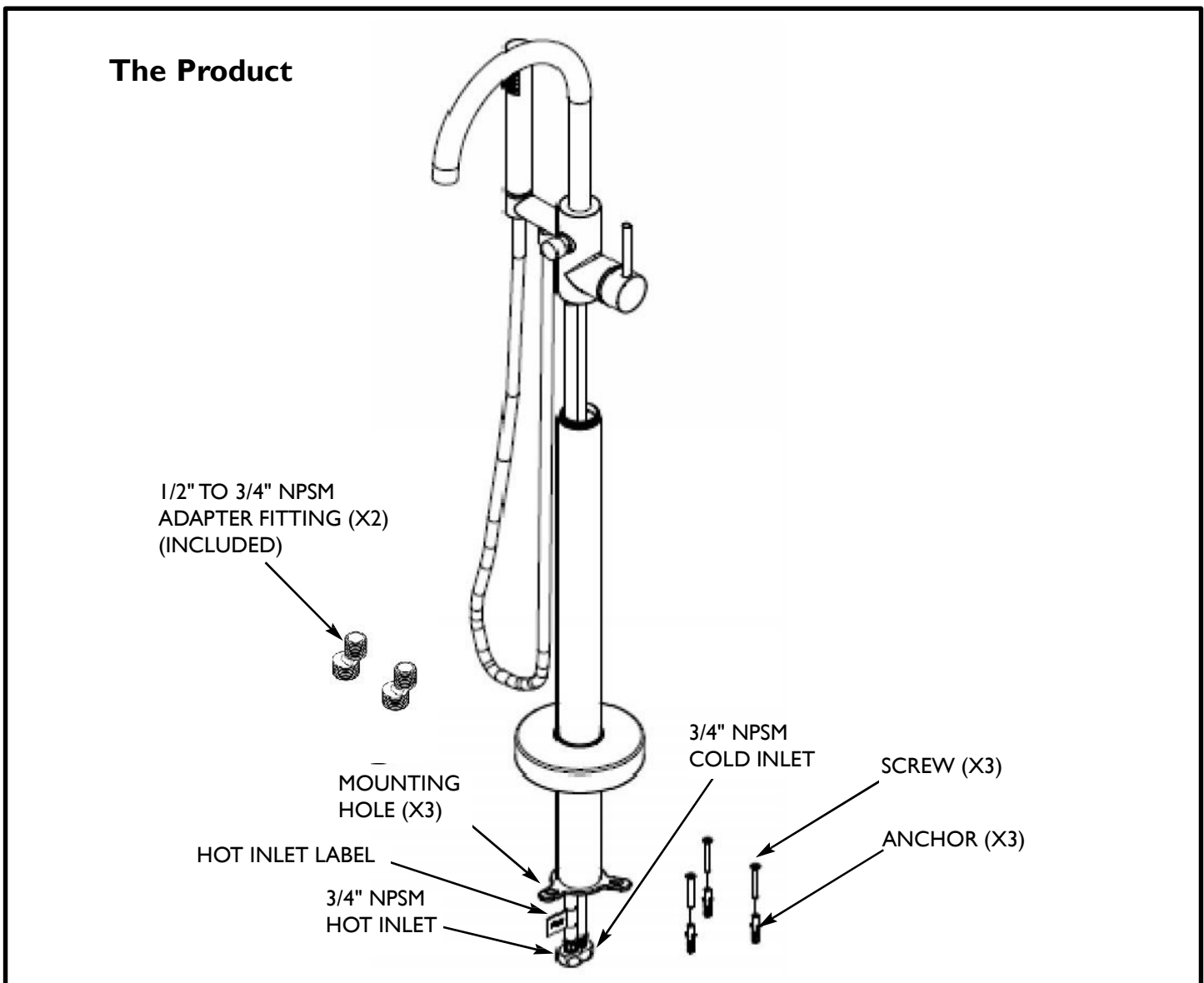

NOTE: Skip to **Installations Step I** if you already installed Brasstech Rough-in pn#I-339. The use of Rough-in I-339 is not required but it will greatly ease the Tub Filler installation.

Site Preparation

NOTICE: This installation instruction assumes the tub filler is mounted on a wood joist support floor surface. For other flooring substrates such as concrete slab, a suitable cavity must be established within the slab at the installation location, along with an on-site fabricated mounting bridge over the cavity to allow for proper mounting of the product. Additionally, the cavity and mounting bridge should be configured to allow for future access to the plumbed supply connections and to provide space for storing the excess length of hot and cold inlet hoses.

I. Installation Clearances: **Figure I** illustrates the minimum distance between the tub filler centerline and a finished wall for preventing handle/wall interference. Maximum distance between tub filler base and inside edge of tub is depicted to ensure water fills tub.

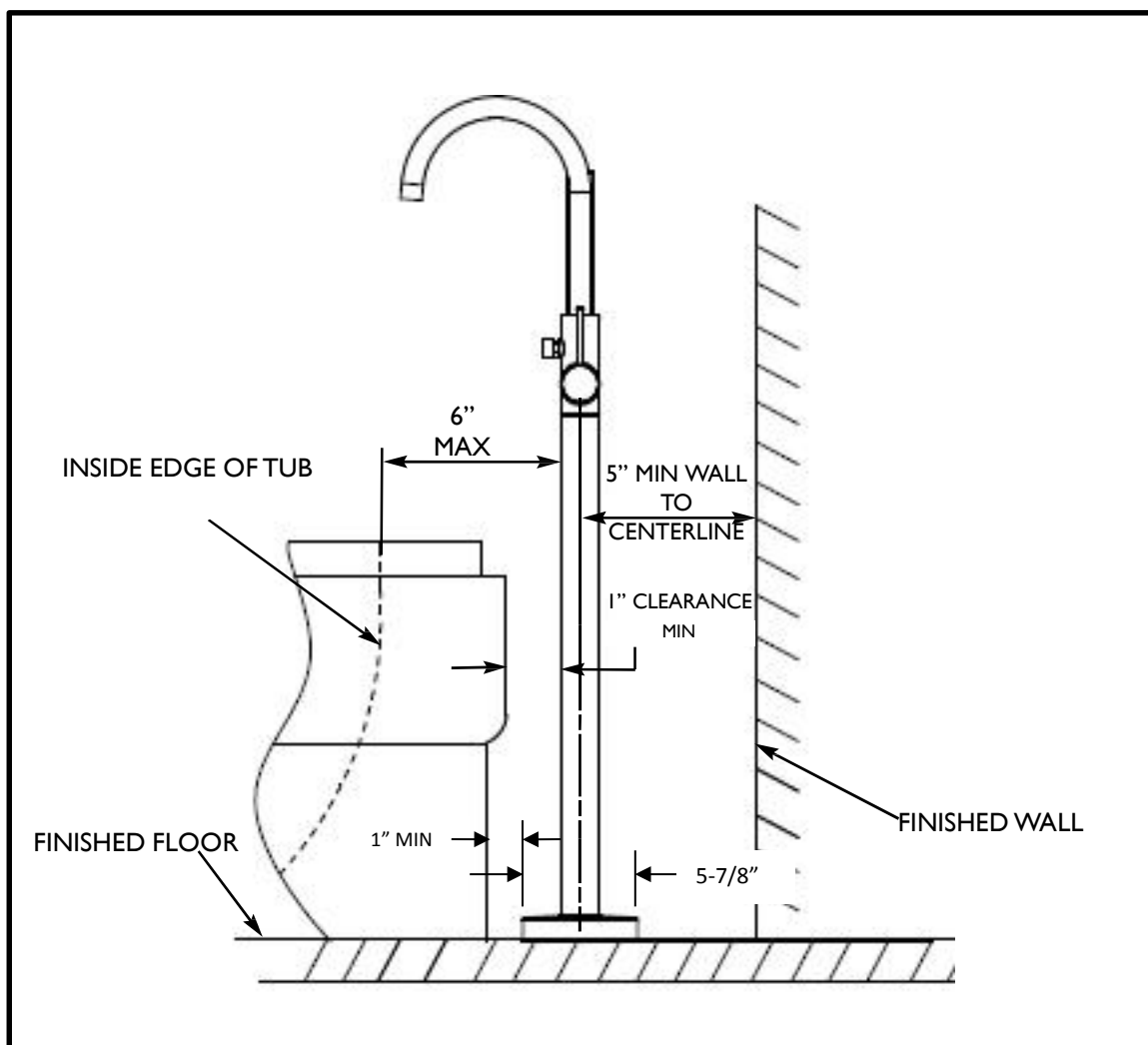

Figure I

Installation Clearances

2. Flooring Substrate / Water Supply Requirements: Figure 2 illustrates the recommended water supply connection and flooring assumptions relative to site preparation.

- a. Diameter of floor opening: 1 7/8" min, 2 1/8" max.
- b. Two FLEXIBLE HOSES (not supplied) are needed to connect water source to tub filler INLETS. The FLEXIBLE HOSE outlets must be installed so as to extend to a minimum of 2 inches above the finished floor.
- c. Tub Filler Inlet Fittings are 3/4" NPSM Female. Use the included ADAPTER FITTINGS (1/2" NPSM to 3/4" NPSM) to connect to the Tub Filler Inlet Fittings if necessary.

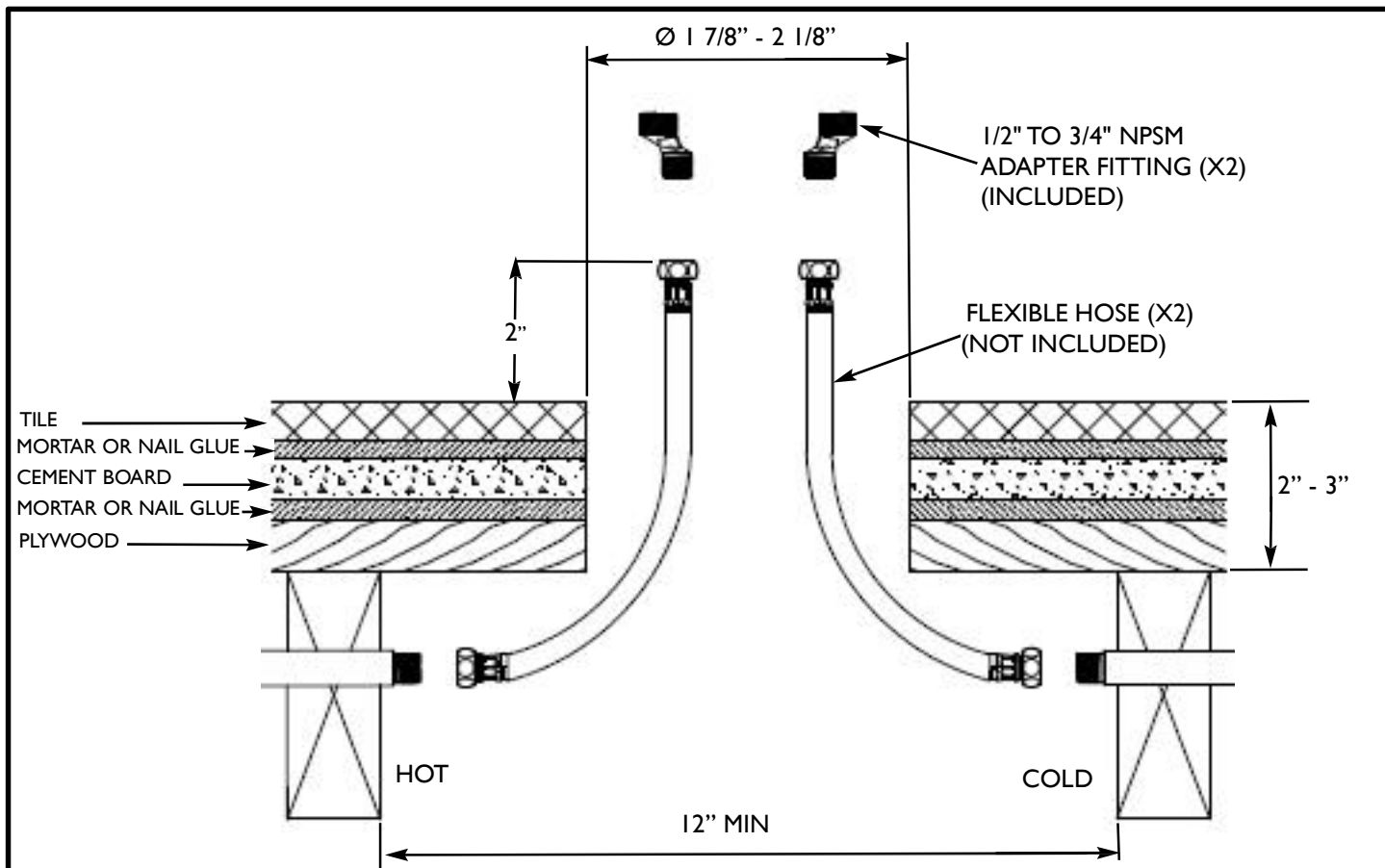

Figure 2
Flooring Substrate / Water Supply Requirements

* Flexible hoses, depicted above, are NOT included.

** Integrity of floor substrate will affect stability of the installed product.

d. Adequate floor support is required. Flooring substrate assumptions:

- i. 2"X8" wood joist support
- ii. 3/4" thick minimum plywood
- iii. 1/4" thick minimum cement board
- iv. 1/4" thick minimum tile or hardwood.

Note: Thin-set mortar (or nail glue) is recommended between subfloor layers outlined above.

e. Leak-free connection of the water supply to the Tub Filler INLETS (3/4"NPSM female thread) is the responsibility of the installer.

Installation Instructions

STEP 1: Assembling the Tub Filler: Figure 3 illustrates the staggering technique required to thread the two $\frac{3}{4}$ " INLETS of the flexible SUPPLY LINES through the TUBING RISER.

- a. Install FLANGE over the TUBING RISER.
- b. Pass the staggered SUPPLY LINES through the TUBING RISER.

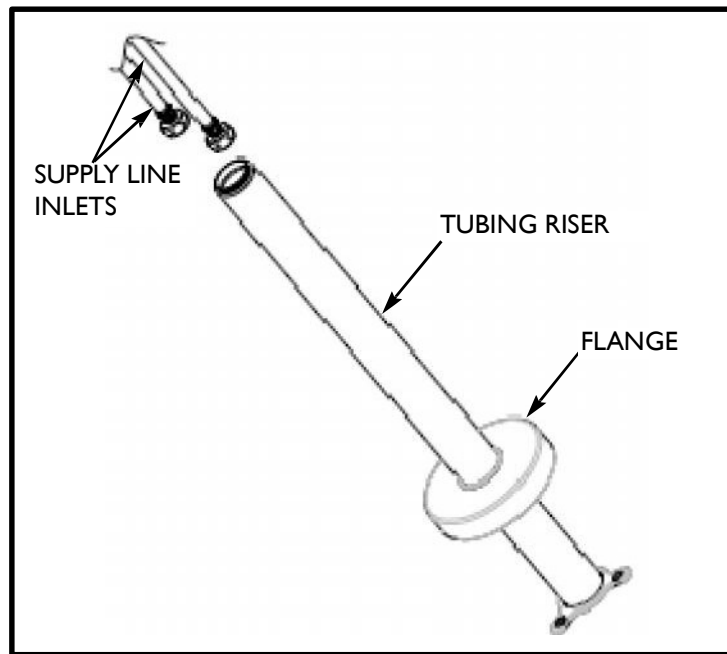

Figure 3

Assembling the Tub Filler

Note: Staggering tub filler inlet fittings will allow them to be threaded through the base.

- c. Attach the Tub Filler MAIN BODY to TUBING RISER.
 - i. With the SUPPLY LINES internal to the TUBING RISER, connect the MAIN BODY to the TUBING RISER as follows depending on Model Number.
 1. Model No. 2480-4261 and 2560-4261: Rotate the male threads of the TUBING RISER into the female threads of the Tub Filler Main Body until snug.
 2. Model No. 2040-4261: Insert TUBING RISER into Tub Filler Main Body and secure with set screw located at the base of the MAIN BODY.
- d. Secure the Spout into position by tightening the set screw located at the top of the Tub Filler MAIN BODY.

STEP 2 (A or B)

A. When used with Brasstech Rough-in Kit I-339

Unscrew the three PHILLIP HEAD SCREWS to remove the ALIGNMENT PLATE as shown in Figure 4. Unscrew and discard the two PLUGS.

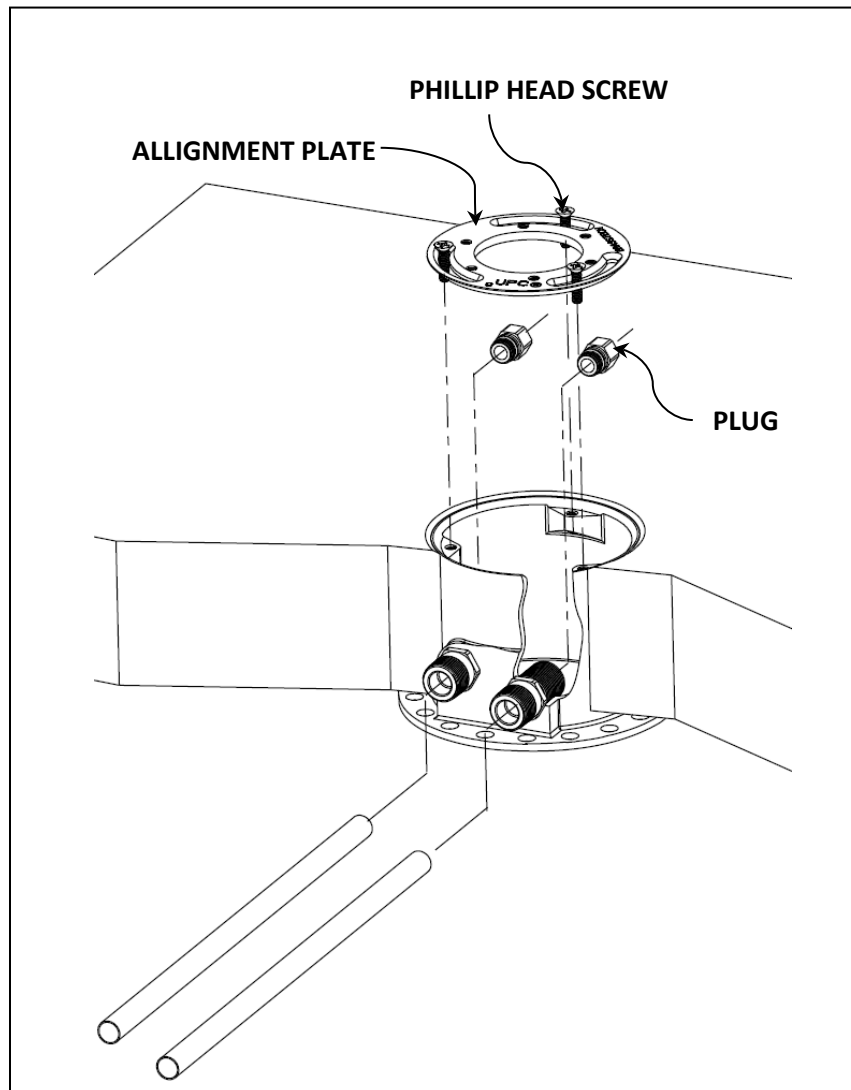

Figure 4
Brasstech Rough-in Kit I-339.

As shown in **Figure 5**, feed the Tub Filler Inlets through the ALIGNMENT PLATE. Use the 3 provided PHILLIP HEAD SCREWS to attach the Tub Filler Bottom Base to the ALIGNMENT PLATE. Place the Tub Filler on the floor and connect the Tub Filler Inlets to the appropriate hot and cold water supply of the Rough-in Kit. Ensure the Tub Filler handle is in off position, turn on water supply to test water connections to confirm water tight seals. Hold the Tub Filler upright and wind the Tub Filler flex hoses counter-clockwise and feed the flex hoses inside the ROUGH-IN HOUSING. Orient the Tub Filler with its spout facing to the desired direction and re-attach the ALIGNMENT PLATE to the ROUGH-IN HOUSING using the remaining 3 PHILLIP HEAD SCREWS. Check for any water leaks again before sliding the BASE COVER down to cover the Rough-in.

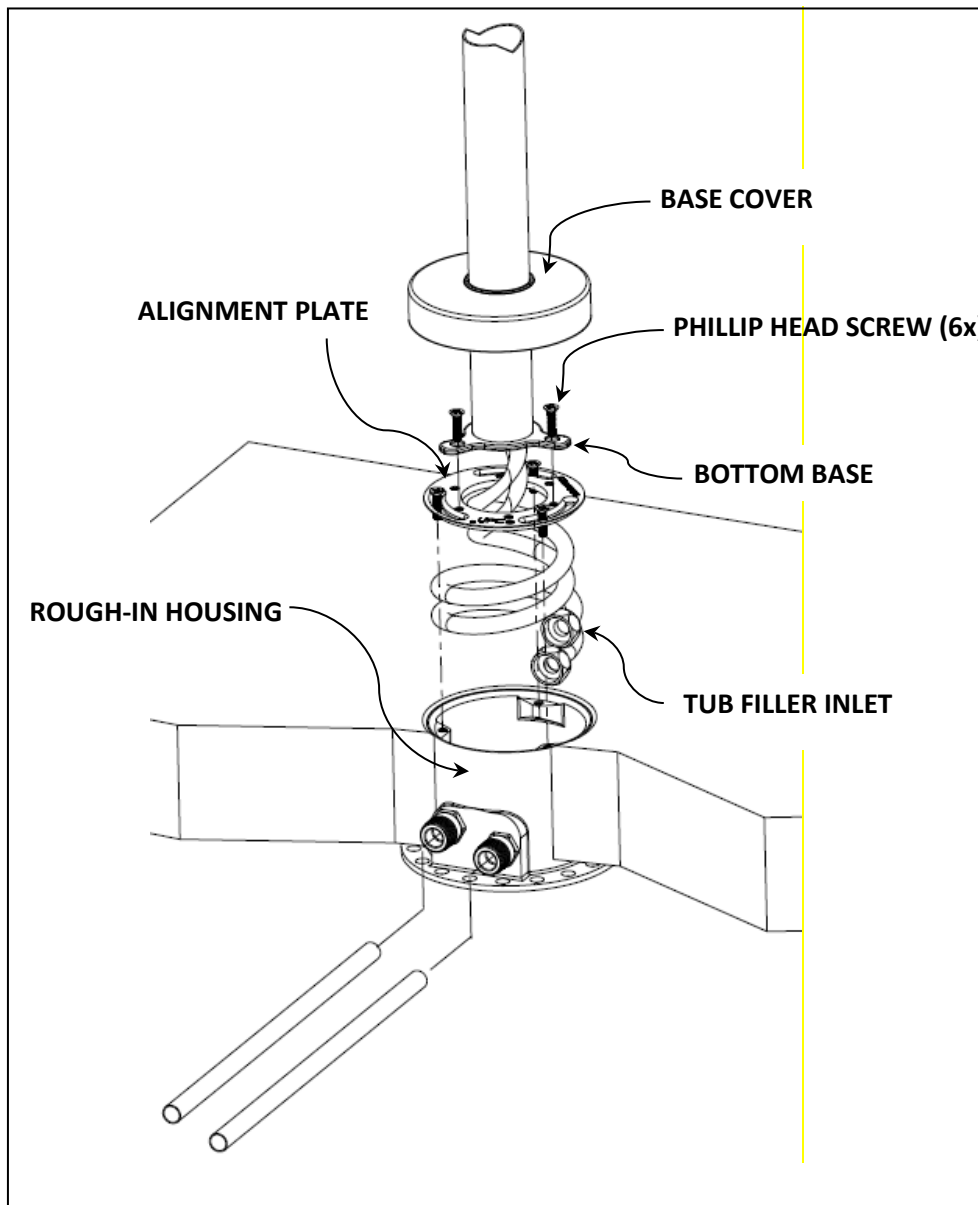

Figure 5
Connecting Tub Filler to the Rough-in Kit I-339

OR

B: When used without Brasstech Rough-in Kit I-339

Connect Tub Filler Inlets to Water Supply. **Figure 6** illustrates the connecting of the Tub Filler INLETS to the 1/2" to 3/4" ADAPTER FITTINGS. Make sure the (hot inlet label) and cold tub filler INLETS connect to the hot and cold of the water supply set-up. The installer is responsible for ensuring a water tight seal.

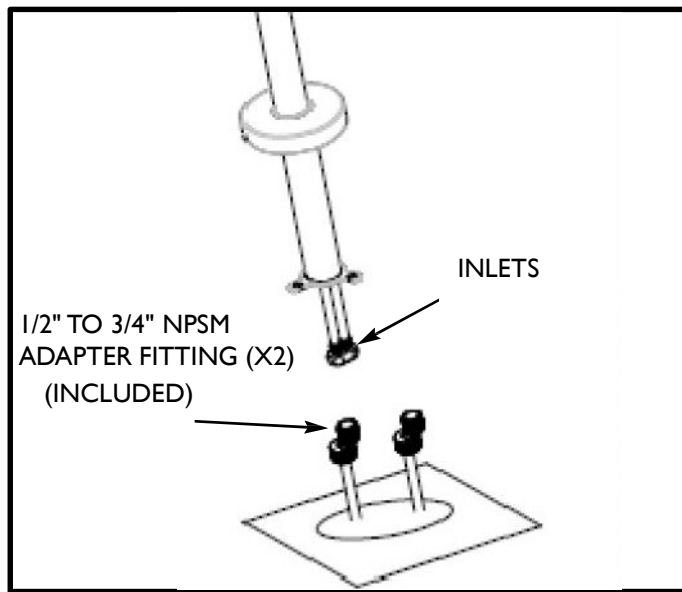

Figure 6

Connecting Tub Filler Inlets to Water Supply.

STEP 3: Pressure Test Water Supply Connection

a. Before attempting to mount the Tub Filler to the floor, Test water connections to ensure water tight seals. The installer is responsible for ensuring a water tight seal. Lay the Tub Filler on the floor and pull the tub filler supply lines above the floor surface to enable leak detection as needed.

STEP 4: Securing the Tub Filler to the Floor: Figure 7 illustrates the hardware required to mount the Tub Filler Riser to the floor.

- a. Gently push down and slide all the flexible hose connections through the floor opening.
- b. Position the tub filler above the floor opening and orient the tub filler spout to the desired orientation with respect to the tub.
- c. Rotate the tub filler LEVER HANDLE to verify that the full rotation will not interfere with the bathing fixture or back wall per **Figure 1**.
- d. Use a pencil to mark the locations of the three BASE ANCHOR HOLES on the finished floor around the opening in the floor.
- e. Lay the tub filler on the floor and out of the way.
- f. Using a drill and a 5/16" drill bit, drill 3 holes, 2" deep at the marked locations. Warning: Care should be taken to avoid damaging the water supply lines during the drilling process.
- g. Insert PLASTIC ANCHORS into the three 5/16" holes. Tap flush to the floor surface with a hammer as needed.
- h. Position Tub Filler TUBING RISER BASE over the inserted anchors.
- i. Drive SCREWS through the TUBING RISER BASE holes and into the anchors until snug.
- j. Slide FLANGE down to the base of the TUBING RISER until flush with the floor.

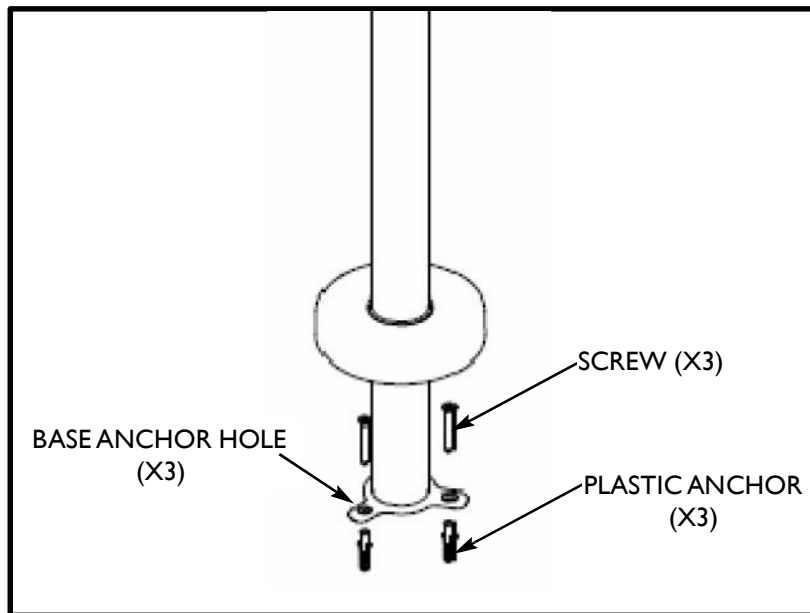

Figure 7

Securing the Tub Filler to the floor.

STEP 5: Install the Hose to the Hand Shower and the Tub Filler: Figure 8 (next page) illustrates installing one end of the HOSE to the HAND SHOWER OUTLET located under the HAND SHOWER HOLDER. Attach the other end of the HOSE to the HAND SHOWER until both are secure.

- a. Place the HAND SHOWER into the HAND SHOWER HOLDER.

STEP 6: Confirm Tub Filler Spout and Hand Shower Functionality

- a. Turn Tub Filler Lever Handle to the ON position initiating flow through the Tub Filler Spout.
- b. Confirm proper Hot and Cold flow through Spout.
- c. Remove the HAND SHOWER from the HOSE and direct towards the bath.
- d. Pull out on the DIVERTER KNOB to direct flow from the Spout to the HAND SHOWER.
- e. With water now flowing through the HAND SHOWER check all HAND SHOWER HOSE connections for leaks and confirm proper flow through the HAND SHOWER.
- f. Turn Tub Filler Lever Handle OFF.

THE INSTALLATION IS NOW COMPLETE.

Contact Newport Brass Technical Support as needed at (949)-417-5207.

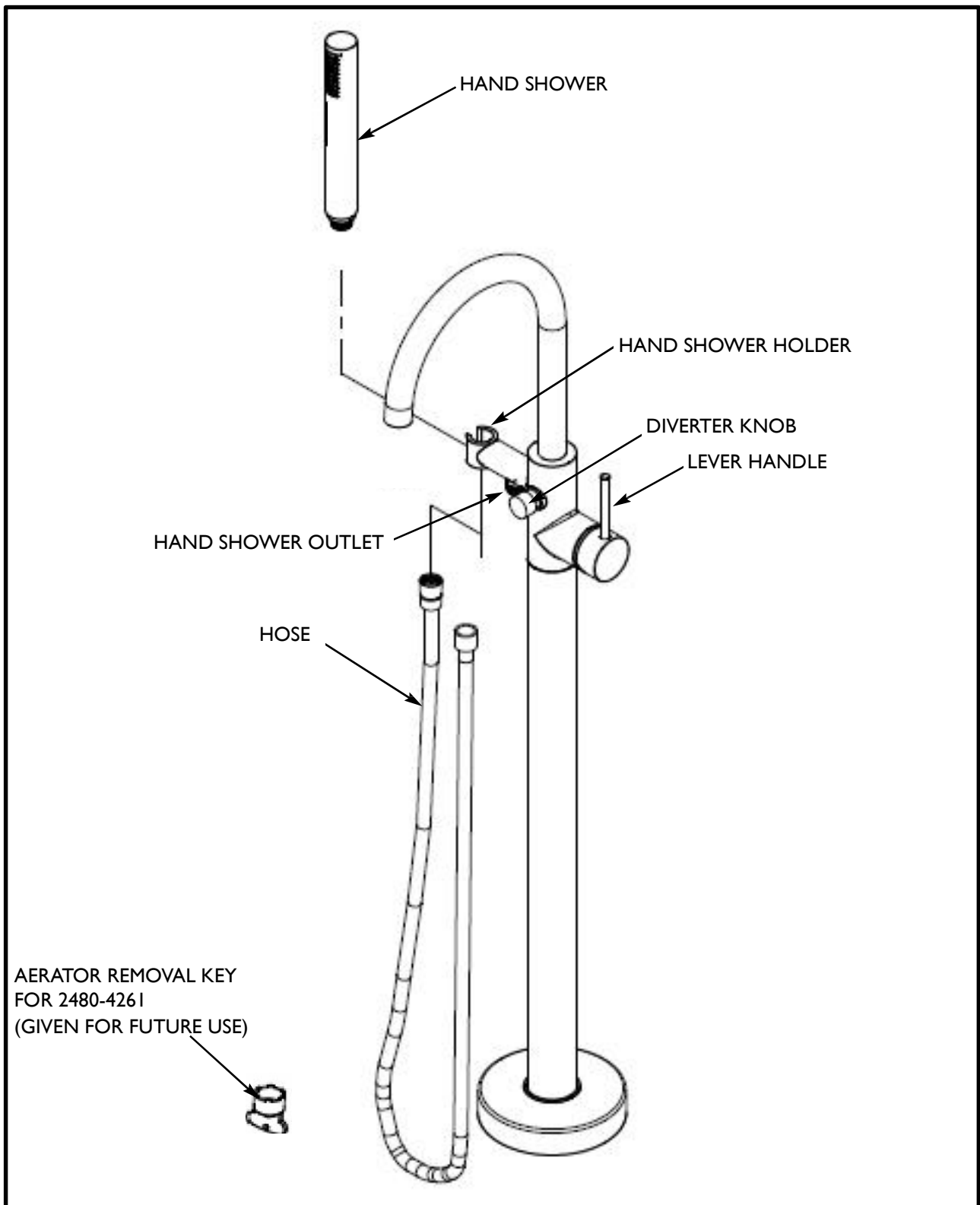

Figure 8

Install the Hose to the Hand Shower and Tub Filler

Disclaimer Regarding Brasstech Free-Standing Tub Filler

To conform to local codes and ordinances, all Brasstech Free-Standing Tub Filler products should be used in concert with an ASSE 1016 approved tempering valve to reduce the hot water supply to a safe temperature not exceeding 110°F (43°C).

Important: Water temperatures in excess 110°F (43°C) are dangerous and may cause scalding, severe injury of death!

Tempering valve should be installed and adjusted by a licensed contractor per the valve manufacturer installation instruction, and in accordance with local codes and ordinances. In general, key characteristics to ensure a tempering valve to work best with Brasstech Free-Standing Tub Filler products shall be as follows:

- Tempering valve should be used prior to the Free-Standing Tub Filler product to reduce the hot water supply to a safe temperature.
- To ensure sufficient water flow through the tub spout, tempering valve should be capable to handle a flow rate of 1.5 GPM or more.
- Tempering valve should include inlet filter washer and check valves in both the hot and cold water inlets to protect against cross flow.

Pressure - Temperature - Flow Rate

PP2SHDW8HVVH SV3D
DPP2SHDW8HVVH SV3D
DPPHW8HVVH SV3D
DPPRW1DW8HPSHDWH

***Note:** Valve should be installed in a location where it is accessible for cleaning or service. Due to the effects of various water conditions, periodic verification of outlet water temperature is required.

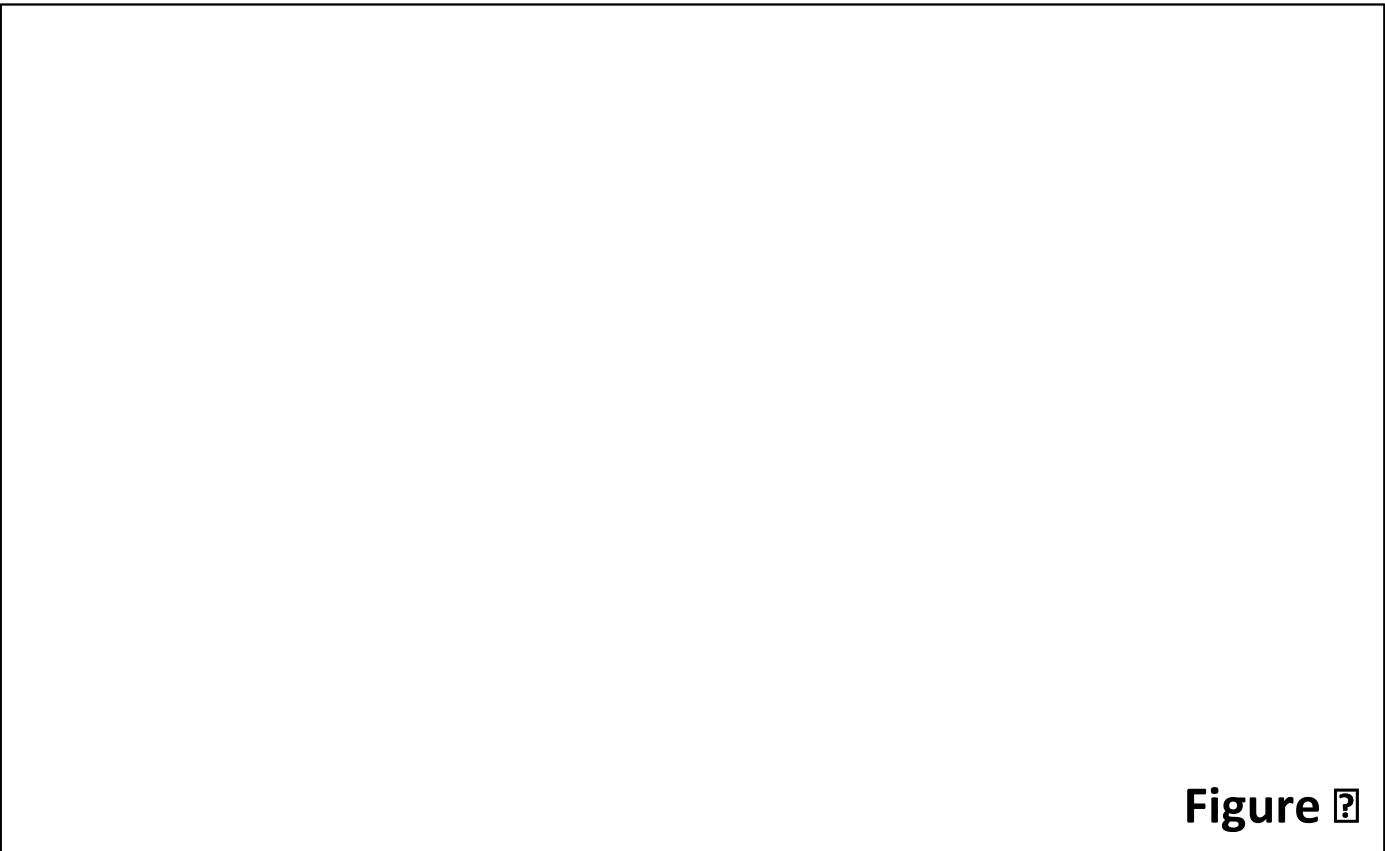

Figure ?