

INSTALLATION INSTRUCTIONS

Tempress Pressure Balancing Valve

Valve Body No. I-594



as used with Shower Fittings

Note: This valve is designed to fit in a 2" X 4" stud wall (or thicker) installation. Use stem extension kit #I-249 (sold separately) if valve installed is too far away from the finished wall.

Description

This valve is precision engineered to provide satisfactory performance provided it is installed and operated in accordance with our recommendations contained in these instructions. In order to fully enjoy the comfort, safety and the reliability of this valve, be certain to familiarize yourself with these instructions.

Operation

The pressure balancing cartridge contained in this valve compensates for pressure fluctuations in the water supply system through a diaphragm-connected pressure balancing mechanism. The outlet temperature will change by no more than a mere $\pm 2^{\circ}\text{F}$ (1°C) with a 50% drop in either the hot or cold water pressure. Even if the coldwater pressure fails completely, the anti-scald design will reduce the flow rate to a safe level ensuring reliable protection against scalding. The built-in check valves prevent cross flow between the hot and cold supplies.

SPECIFICATIONS			
Min. Operating pressure:	20 psi [140 KPa]		
Max. Operating pressure:	125 psi [860 KPa]		
Max. Burst pressure:	500 psi [3450 KPa]		
Max. Hot water temp.:	180°F [80°C]		
Flow rate in USGPM [l/min] @ 50 psi [345 KPa]:			
	Tub	Shower	
3P 3-Port:	-	-	5.3 [20]
ID Diverter (Automatic):	6.5	[25]	5.3 [20]

Illustration I

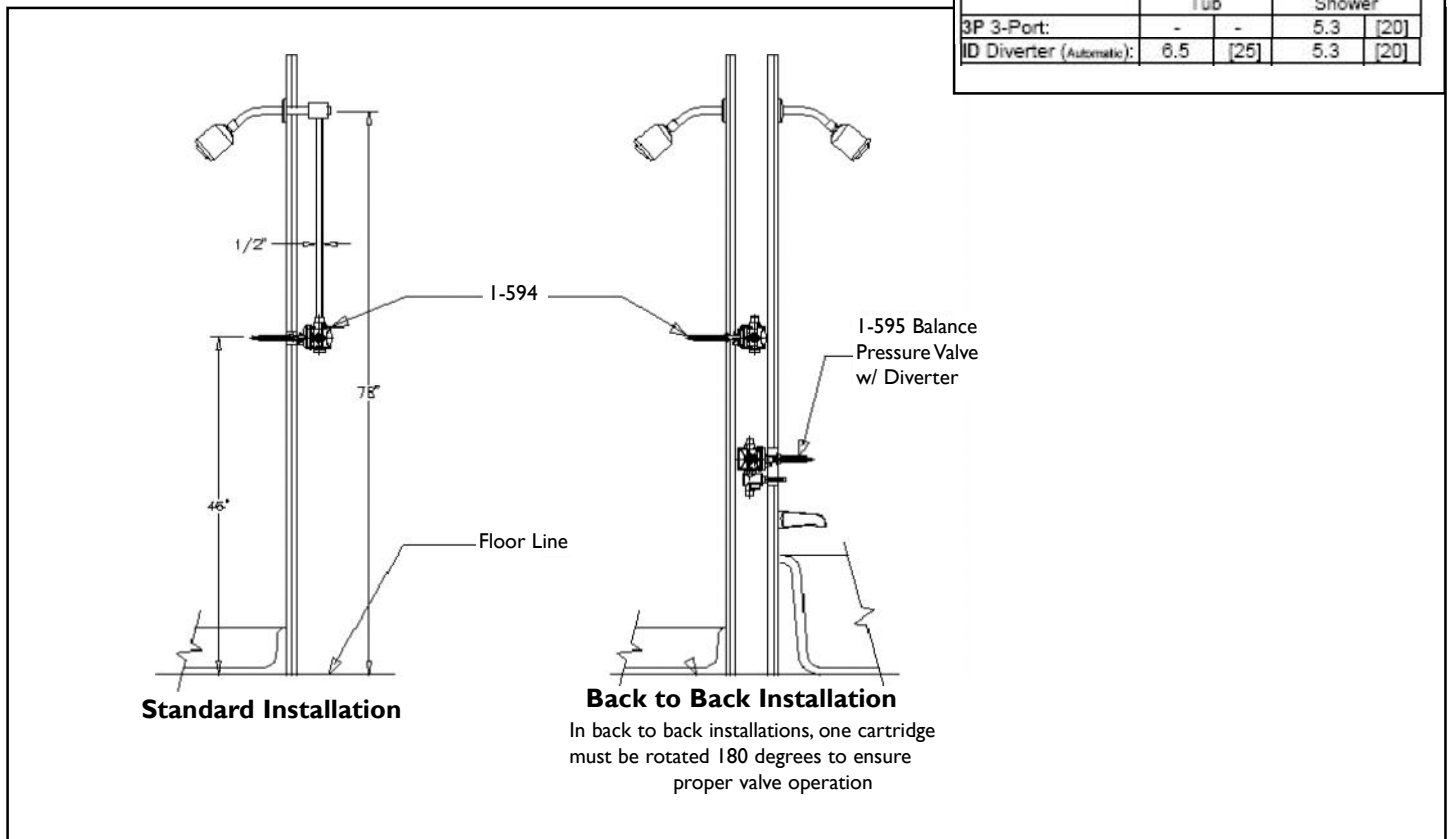

Before you begin

Make sure valve is securely fastened to studs. Be sure to remove trim items, handles, escutcheons and plates before installation. Wrap carefully and store until finished wall is completed.

Install the valve by positioning the 1/2" shower outlet in the up position. Finished wall must be within dimensions shown on the chart below.

On tiled wall surfaces, grouting must be either flush or raised for proper sealing of the cover plate.

IMPORTANT: It is not necessary to remove the cartridge from the valve during **NORMAL** soldering operations using propane-butane gas. **DO NOT USE OXYGEN-ACETYLENE.** When soldering CxC connections, do not solder within 4" of valve port. Open the stop valves when soldering inlets.

To test pipe joints, pressurize both hot and cold inlets.

Installing Trim

Place cover plate on valve stem and slide into position. Install escutcheon/bonnet trim and mark the all-thread nipple, (Item 1) where excess needs to be trimmed.

Remove escutcheon/bonnet trim and cut all-thread nipple 1/16" less than indicated mark to prevent exposure of nipple threads. **NOTE:** Do not cut stem, (Item 6), or all-thread nipple until finished wall is complete and a dimension check of handle and escutcheons/bonnet trim is done. (Stem is grooved at 1/2" intervals) Cut stem at least 1/2" past the end of the cut all-thread nipple. Final stem length may vary based on individual handle base insertion. Reinstall escutcheon/bonnet trim and handle. Secure handle into place by tightening the handle setscrew. (Ref. Illustrations 2 & 3) Turn on water supply to check for leaks.

Illustration 2

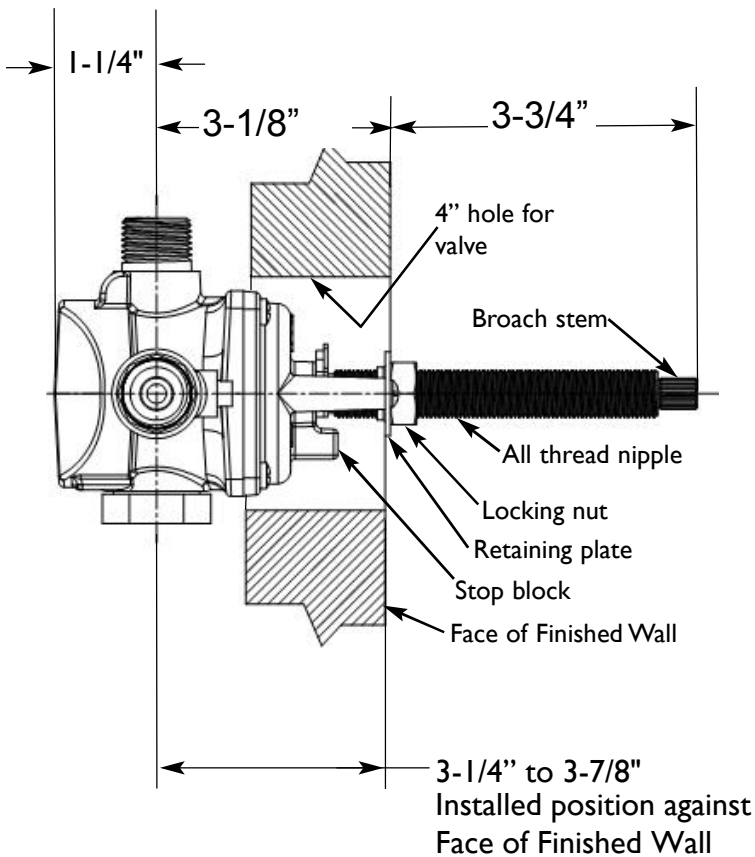

Ensure that the stop ring (3) is correctly installed as follows:

- Rotate the cartridge stem (13) fully clockwise.
- Position the stop ring on the stem such that it rests against the stop post (14).

The stop ring must be correctly installed prior to finish trim installation.

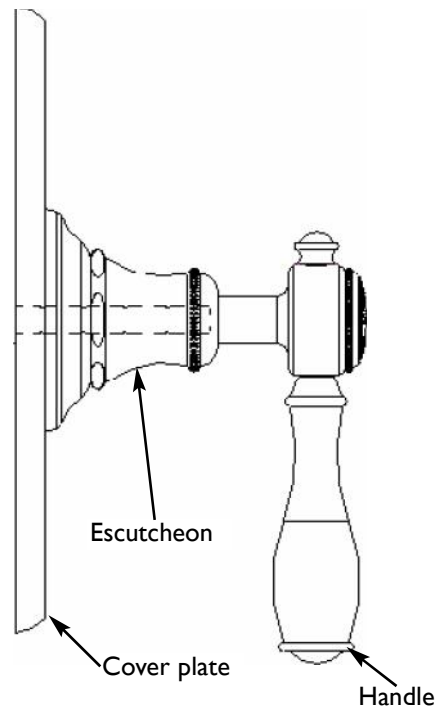
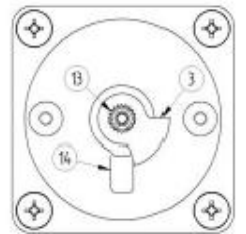

NOTE: Dimensions shown are from the inlet ports to the finished wall.

Illustration 3

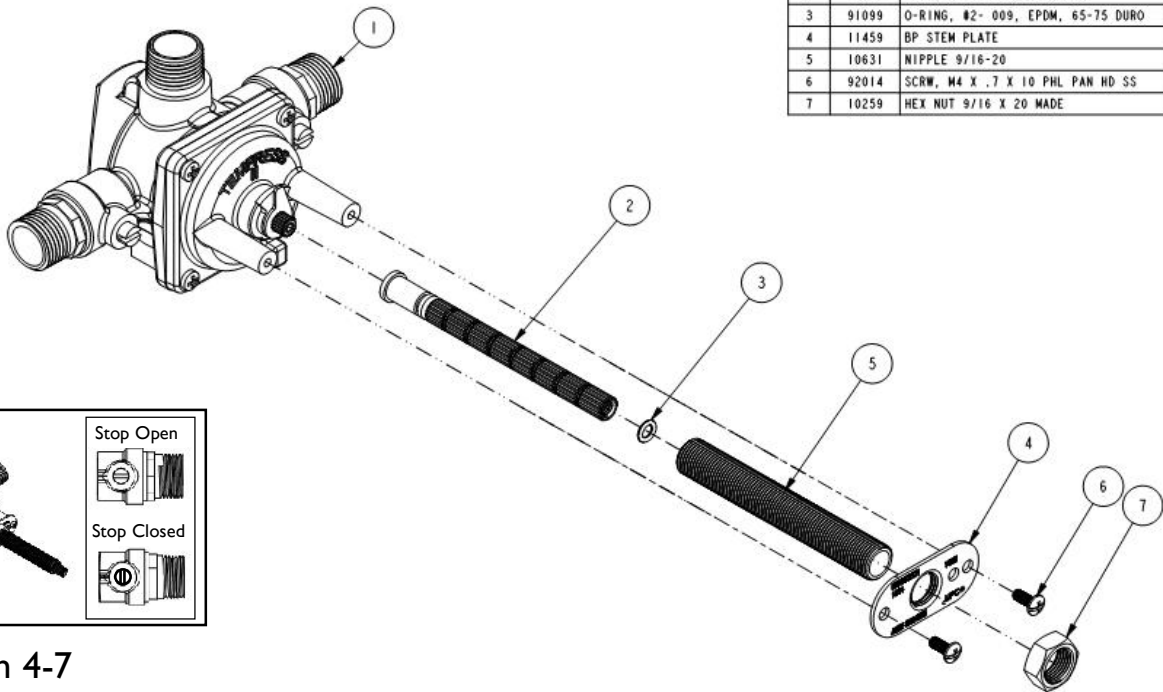

BILL OF MATERIAL (CURRENT LEVEL)				
ITEM	PT/ASSY	DESCRIPTION	TYPE	QTY.
1	1-208	BP VALVE ASM W/O DIVERTER	ASSEMBLY	1
2	11349	STEM,16T- EXT FULL BROACH	PART	1
3	91099	O-RING, #2- 009, EPDM, 65-75 DURO	PART	1
4	11459	BP STEM PLATE	PART	1
5	10631	NIPPLE 9/16-20	PART	1
6	92014	SCRW, M4 X .7 X 10 PHL PAN HD SS	PART	2
7	10259	HEX NUT 9/16 X 20 MADE	PART	1

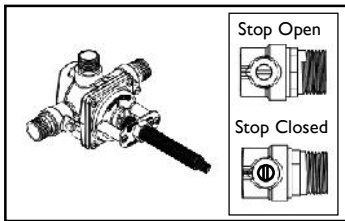
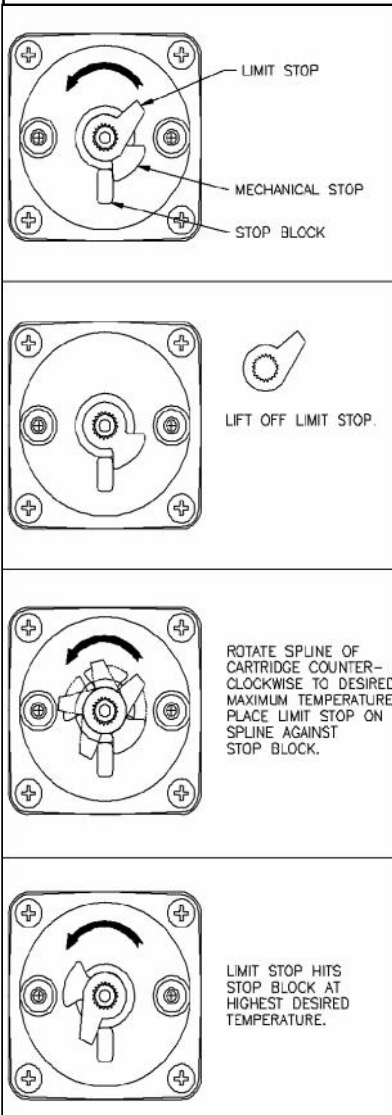

Illustration 4-7



Setting the Temperature Limit Stop

This valve has an upper temperature limit stop, which can allow desired and safe hot water temperature (recommended maximum is 110°F). This stop may be adjusted once the valve is installed. Before making this adjustment, run the water with the valve turned to the hot setting. If the water temperature is too high in this position, then perform the following adjustments:

- Remove the trim (handle, escutcheon and cover).
- Remove the all-thread nipple, retaining screws and retaining plate.
- Remove the broach and the limit stop. Do not remove the mechanical stop.

If for any reason the mechanical stop or the cartridge is removed, the following steps must be performed:

1. Close the valve by turning the cartridge stem clockwise until it stops, (Do not forcefully rotate).
2. Position the mechanical stop on the cartridge against the stop block as shown in Illustration 5 and continue with the following steps.

- From the CLOSED position, rotate the cartridge stem counter-clockwise until the desired temperature is achieved.
- Place the limit stop on the cartridge stem against the stop block as shown in Illustration 7. Rotate several times to make sure the stop is at the desired temperature setting.
- Replace the full extension broach, retaining plate and screws, all-thread, nipple and locking nut. (NOTE: For stem to be fully seated into cartridge, all-thread nipple and locking nut must be tightly secured against retaining plate.)

* **WARNING** - Never try to stop dripping by applying extreme force or overtightening the handle.

MALFUNCTION	CAUSE	REMEDY
Opening immediately to hot water.	Hot and cold water supplies have been connected in reverse.	Rotate cartridge. (See Page 3)
Water drips after shutting off the valve.	Residual water in valve and piping.	Allow approximately 3-8 minutes to drain.*
	Incorrect setting of the mechanical stop against the stop block causing a partially opened cartridge.	Reset the mechanical stop. (See Page 3)
	O-ring seal on the inlet of the cartridge is faulty or seat assembly is damaged.	Check the O-ring & seat for cuts or overheating damage during installation. Replace if necessary.
Water insufficiently hot.	Adjustable handle position stop incorrectly set.	Refer to the instruction on "Setting Temperature Limit Stop".
Valve body too deep into wall.	The measured rough in or finished wall surface is incorrect.	Reset the valve.
Diverter will not stay on during shower.	Not enough backpressure between showerhead and diverter valve.	Flow restrictor @ shower head 2.5 GPM
No or low flow of hot or cold water.	Either the hot or cold side is not fully pressurized.	Verify that all service stops for both the hot and cold are fully open and pressurized.
	Debris caught inside the inlet of the cartridge.	Remove the cartridge (See Page 3). If debris is lodged in the inlet of the cartridge or check the valve located in the cast valve body. The debris can be removed with a straightened paper clip or fine wire. Gently insert the wire and move it in a circular motion to dislodge any debris.